

# VitaPump<sup>TM</sup>

Vitamin Metering System

## Operations Manual

Rev.C, 08/04

Manual, Software & Applications Copyrighted  
SciLog Inc.



## WARRANTY POLICY, PRODUCT RETURNS, ACCEPTABLE USE, AND OTHER RESTRICTIONS

### 1. WARRANTY AND RETURNS POLICY:

SCIOLOG, INC. EXPRESSLY WARRANTS THE EQUIPMENT MANUFACTURED BY IT ONLY AS SET FORTH HEREIN. SCIOLOG, INC. MAKES NO OTHER WARRANTIES, EITHER EXPRESS OR IMPLIED (INCLUDING WITHOUT LIMITATION WARRANTIES AS TO MERCHANTABILITY OR FITNESS FOR A PARTICULAR PURPOSE). IN ADDITION, THE FOLLOWING SHALL CONSTITUTE THE SOLE AND EXCLUSIVE REMEDIES OF BUYER FOR ANY BREACH BY SCIOLOG, INC. OF ITS WARRANTY HEREUNDER.

**A. PRODUCT WARRANTY** – SciLog, Inc. warrants products it manufactures against defects in materials and workmanship for one (1) year from the date of shipment from SciLog, Inc. in normal use and service. If any products fail to conform to this warranty within the first ninety (90) days of the warranty period, SciLog, Inc. will, at its option, repair or replace such goods returned. If any products fail to conform to this warranty for the remainder of the warranty period, SciLog, Inc. shall furnish necessary replacement parts free of charge.

**B. PARTS WARRANTY** - SciLog, Inc. warrants service parts against defects in materials and workmanship for ninety (90) days from the date of shipment from SciLog, Inc. in normal use and service. If any service parts fail to conform to this warranty, SciLog, Inc. shall furnish necessary replacement parts free of charge.

**C. WARRANTY LIMITATIONS** - These warranties are subject to the following conditions:

1. Upon discovery of such non-conformity, SciLog, Inc. will be given prompt written notice with a detailed explanation of the alleged deficiencies.

2. The product or part must be properly installed, operated and maintained in accordance with SciLog, Inc. specifications.

3. The product or part must not be operated above rated load capacity or subject to accident, alteration, misuse, or abuse.

4. The product must not have been repaired or serviced by anyone other than SciLog, Inc. or one of its authorized dealers.

5. SciLog, Inc. shall have a reasonable time to repair or replace the effective product.

6. The buyer is responsible for shipping the product to SciLog, Inc. SciLog, Inc. is responsible for shipping the product back to the buyer.

**D. RETURN POLICY** - Any item may be returned within thirty (30) days from the date of shipment from SciLog, Inc. If the box is unopened (the original factory seal is intact), SciLog, Inc. will refund the full credit to the buyer. If the box is opened (the original factory seal is not intact), SciLog, Inc. will refund the full credit less a \$75 inspection fee and repair labor/parts/materials cost (if applicable) to the buyer. No returns will be accepted after thirty (30) days from the date of shipment from SciLog, Inc. The buyer is responsible for shipping the product to SciLog, Inc.

### 2. INTELLECTUAL PROPERTY

The sale and delivery of the SciLog, Inc.'s equipment and/or software to Buyer shall in no way transfer to Buyer any right of ownership in any patents, copyrights, trademarks, technologies, designs, specifications, drawings, or other intellectual property incorporated into the equipment and/or software.

### 3. DISCLAIMER OF DAMAGES

IN NO EVENT SHALL SCIOLOG, INC. BE LIABLE FOR ANY TYPE OF SPECIAL CONSEQUENTIAL, INDIRECT, INCIDENTAL OR PENAL DAMAGES, WHETHER SUCH DAMAGES ARISE OUT OF OR ARE A RESULT OF BREACH OF CONTRACT, WARRANTY, TORT (INCLUDING NEGLIGENCE), STRICT LIABILITY OR OTHERWISE. Such damages shall include but not be limited to loss of profits or revenues, loss of use of the equipment or associated equipment, cost of substitute equipment, facilities, down time costs, increased construction costs or claims of Buyer's customers or contractors for such damages. Buyer agrees that in the event of a transfer, assignment, or lease of the equipment sold hereunder Buyer shall secure for the SciLog, Inc. the protection afforded to it in this paragraph.

### 4. LIMITATION OF LIABILITY

The SciLog, Inc. shall not be liable for any loss, claim, expense or damage caused by, contributed to or arising out of the acts or omissions of Buyer or third parties, whether negligent or otherwise. In no event shall the SciLog, Inc.'s liability for any cause of action whatsoever exceed the cost of the item giving rise to the claim, whether based in contract, warranty, indemnity, or tort (including negligence). Any suit arising hereunder must be commenced within one (1) year from the date in which the cause of action accrues. Except as provided in Article 3, the SciLog, Inc. shall not indemnify any party.

### 5. NO RESPONSIBILITY FOR GRATUITOUS INFORMATION OR ASSISTANCE

If SciLog, Inc. provides Buyer with assistance or advice which concerns any parts, products, service supplied hereunder or any system or equipment in which any such part, product or service may be installed and which is not required pursuant hereto, the furnishing of such assistance or advice shall not subject SciLog, Inc. to any liability, whether based in contract warranty, tort (including negligence) or otherwise.

### 6. INTERNATIONAL SALES EXPORT

Buyer EXPRESSLY agrees and verifies that the purchased product(s) will not be transferred or exported to third parties or foreign nationals and that Buyer is the final end-user of the product. Export or transfer of any SciLog product without the EXPRESS written authorization of the SciLog, Inc. is strictly prohibited and may violate US trade laws and regulations, thereby subjecting the Buyer to civil and criminal liability.

### 7. REVISIONS TO THIS POLICY

From time to time the Company may revise the terms of this Agreement. Company will make its best efforts to inform customers of these revisions. The most current revision of these terms may be accessed over the internet by accessing the webpage located at: <http://www.scilog.com/warranty>

**REGISTER YOUR PRODUCT(S) WITH SCIOLOG, INC. IMMEDIATELY AT:**

<http://www.scilog.com/register>



Phone: 608-824-0500 Fax: 608-824-0509  
8845 South Greenview Drive, Suite 4  
Middleton, Wisconsin 53562 USA

# VitaPump Maintenance

A factory cleaning, testing and recalibration should be performed to your VitaPump at least once every two years.

**Fill Out this Form & Fax it to SciLog at FAX: 608-824-0509.**

1. SciLog will disassemble, clean and lubricate the pump head, change the seals if appropriate, test, recalibrate and generate a Performance Validation for your VitaPump. If your pump needs a new motor or pump head, then we will contact you & get your approval before replacing them. A new motor is \$350; a new Q1 piston head is \$645; a new peristaltic Tandem head is \$235. Most of the time, cleaning and recalibration is all that is needed to insure many years of service. Price includes the cost of SciLog shipping your pump back. \$350
2. Scilog will send you a loaner pump for one week if you request it. This price includes the cost of next day shipping & insurance to send the loaner to you. \$350
3. Use the packing material from the loaner & send your pump to:  
SciLog Inc.  
ATTN: RGA# \_\_\_\_\_  
8845 S. Greenview Dr.  
Middleton, WI, 53562  
Be sure to call SciLog for an RGA#, and write this on the box.
4. Once you receive your cleaned/repared VitaPump, use the packing material to repack the loaner and send it back to SciLog.

Assuming no replacement parts are required,  
**Total Cost, including Loaner and Shipping:**

**\$600**

**Please Check all of the following that are appropriate:**

**Yes, I need my VitaPump cleaned and recalibrated.**

**Yes, I need a loaner VitaPump sent to me.**

**PO#** \_\_\_\_\_ **or Credit Card#** \_\_\_\_\_  
Credit Card Expiration Date \_\_\_\_\_

**Send the Loaner and/or Repaired / Cleaned VitaPump to:**

**Company:** \_\_\_\_\_

**Address:** \_\_\_\_\_

\_\_\_\_\_

**Contact:** \_\_\_\_\_

**Contact Phone #:** \_\_\_\_\_

**Contact Fax #:** \_\_\_\_\_

**Contact Email:** \_\_\_\_\_

**Call SciLog Customer Service at 800-955-1993 with any questions.**



## Table of Contents:

<b>VitaPump Maintenance</b> .....	2
<b>Start-up: “Vitamin Addition by Weight”</b> .....	4
<b>Installation &amp; Start-Up</b> .....	10
<b>Introduction:</b> .....	12
<b>VitaPump™ Specifications: Summary</b> .....	14
<b>Part A: Hardware</b> .....	15
<b>1.0 VitaPump™: Overview</b> .....	15
<b>2.0 Front Panel:</b> .....	16
<b>3.0 Back Panel:</b> .....	17
<b>Part B: Software</b> .....	18
<b>1.0 Main Menu</b> .....	18
<b>2.0 Vitamin Metering: Edit / Alarms</b> .....	20
<b>3.0. Metering: Exec</b> .....	21
<b>4.0 Setup: Edit</b> .....	22
<b>4.10 Setup: Scale</b> .....	24
<b>4.4 Printer Documentation:</b> .....	29
<b>4.7 Setup: External Run/Stop</b> .....	30
<b>5.0 Serial Mode: Remote Control by PC: Printer &amp; PC Control</b> .....	31
<b>5.1 Printer: Commands &amp; Data format</b> .....	31
<b>5.2 PC Control: Commands and Data format</b> .....	32
<b>5.3 Win95/98 HyperTerminal Settings:</b> .....	33
<b>6.0 Manual Mode</b> .....	34
<b>Appendix “A” Tandem Pump Head Installation and Maintenance</b> .....	35
<b>Appendix “B” FMI Q1 Pump Head Installation and Maintenance</b> .....	40

# Start-up: “Vitamin Addition by Weight”

**Equipment:** You will need the following items to get started:

SciLog P/N	Description	Quantity
	Appropriate Vitamin Reservoir	1 pc
100-138VITA	VitaPump w/ 1081 Peristaltic Head	1 pc
100-4100	Ohaus Explorer Balance, 4100 gm x 0.1gm	1 pc
400-214	Tygon Tubing, Food Grade, #14	25 ft (1 pkg)
080-066	Cable, Interfaces Ohaus Balance and VitaPump	1pc
080-074	Connector w/2 Cables, Alarm & Remote On/Off	1 pc
080-095A	Printer Kit, includes Printer, Cable, 6 rolls Paper	1 kit
Or		
080-073	Cable, Interfaces PC with VitaPump	1 pc

## Hardware Setup:

1. Unpack all the components, visually identify and inspect for damage.
2. At the dispensing station, place the Balance to the far left, with the Vitamin Reservoir on it. Place the VitaPump to its right and the Printer, if you are using one to the right of the pump. This arrangement can be varied depending on the installation location. The VitaPump and Balance in most dairy installations are in an enclosed cabinet to protect the unit.
3. Connect the interface cable between the VitaPump and the balance paying close attention to the labels on the cable and those on the rear of the VitaPump. The “Pump” end of the cable is connected to the “Balance” connector on the rear panel of the VitaPump. The “Balance” end of the cable plugs into the output connector on the rear of the balance. (The cable may ship attached to the balance already, and if so, simply attach it to the VitaPump.) Connect the Printer cable between the “Printer” connector on the rear panel of the VitaPump and the connector on the Printer. If you are using a PC instead of the Printer, connect the PC interface cable to the “Printer” connector on the rear of the VitaPump and COM1 of your computer. You cannot use a printer and PC simultaneously.
4. Connect the Alarm and Remote On/Off cable connector to the “External I/O” connector on the rear of the VitaPump. The Remote On/Off Cable can be connected to your PLC flow control switch. This is a normally open contact closure connection; no power is required or supplied. It acts as a ‘fail-safe’ for your system as the VitaPump will not meter vitamins if this feature is enabled and the switch is in the open position. Connect the Alarm Cable to the PLC or remote alarm control. This provides a low current, 5volt control signal, it will not drive the alarm on its own, only control it.
5. Plug in and power up the system, Balance, Printer and VitaPump, in that order please.
6. Cut enough of the #14 tubing to allow 3-4 feet between the reservoir and the VitaPump, and still leave enough to reach the injection point of your process stream.

7. Route the tubing from the reservoir to the VitaPump, open the head by rotating the lever 180 degrees counter-clockwise, and place the tubing over the upper set of rollers. Confirm that the tubing is under the centering springs and close the head by rotating the lever back to its original position.
8. Route the remaining tubing to the injection point of your process stream and attach it appropriately.

## Program Editing and Execution:

1. At this point, you need to consider the parameters of the addition that you are doing and the information you need from the VitaPump. The following is a list of the various parameters and alarms available. Adjust these parameters based on your dairy's needs and systems. Consult the noted sections of the VitaPump Manual for more information.

- a. **Vitamin Metering: Exec/Edit**, Section 7.0, Pg. 19

**PUMP/MASS RATE:** Defines the weight to be metered in grams/minute. For example, if you want to meter 10.00 gm/min, use the "Incr" and "Decr" keys to scroll to 10.00 and press "Select". (The default PUMP/MASS RATE=6.00gm/min)

**DIRECTION:** Defines the rotation of the pump head, this parameter can be changed from clock-wise (CW) to counter clock-wise (CCW). (Default = CW)

- b. **Vitamin Metering: Alarms**, Section 8.0, Pg. 20

All the Alarms have 3 options: "Off", "Beep Only", and "Pump Stop". "Off" disables the alarm. "Beep Only" gives an audible alarm and continues pumping. "Pump Stop" gives an audible alarm and stops the pump. **Use Pump Stop for all critical alarms.** When the pump rate alarm is activated, the pump is running at 100%. After pressing any key to disable the alarm, you must press EXIT, and then Exec to re-enter the metering program.

**ALARM: PUMP RATE:** The VitaPump will maintain the pump rate based on feedback from the balance. When it is unable to maintain the rate (E.G. when the vitamin reservoir is empty), it will increase its speed to compensate. If it reaches 100% of motor speed for 30 seconds, it will activate the pump rate alarm. This is considered a critical alarm, and should be set to "Pump Stop" to avoid over/under fortification.

**ALARM: WEIGHT ALARM:** Allows the setting of a Batch Weight to provide an alarm when the set weight is reached. Generally used as a warning that a bottle of vitamins is nearly empty. When used, the usual setting is "Beep Only". (Default = Off)

**ALARM: BATCH WEIGHT:** If Weight Alarm above is enabled enter a Batch Weight here. This is usually set to the weight of a full bottle minus 5%.

2. For this example, use the default pump rate of 6 gm/min. Press the EXIT key on the front panel until you reach the Mode Select screen. From the Mode Select screen, use "A" or "B" to go up or down to the "Metering" mode. You will see following display:

Mode Selct	METERING	
Up	Down	Select
A	B	C

3. Press "C" to select, and the following screen is displayed:

<b>- VITAMIN D -</b>		
<b>Exec</b>	<b>Edit</b>	<b>Alarm</b>
<b>A</b>	<b>B</b>	<b>C</b>

4. At this point, you may press “**C**” again to enter the “**ALARM**” submenu and configure them as discussed above. You may also press “**B**” to enter the Edit Menu to change the flow rate or the pump direction. When ready, press “**A**” to Execute the program, and the display will show the following:

↓

<b>SCALE INITIALIZATION</b> <b>Please Wait</b>
---

↓

<b>VITAMIN D:      6.00g/m</b> <b>Press RUN When Ready</b>
---

5. Press the “**RUN**” key on the front panel, or close the flow control switch in your process, and the VitaPump will Tare the scale and begin metering. The following is displayed:

↓

<b>REMOVING TARE WEIGHT</b> <b>Please Wait</b>
---

↓

<b>PR = 6.00 g/m      RUN</b>
<b>TW = 0000.000    BW = 0.000</b>

**PR** = Pump Rate (grams/minute).

**TW** = Total Weight (kilograms). This a long-term cumulative weight, designed for weekly, monthly, or longer recording of vitamins dispensed. It should only be reset with a supervisor’s approval.

**BW** = Batch Weight (kilograms). This weight is reset every time the metering program is exited and re-executed, i.e. when the vitamin bottle is changed.

**NOTE:** The Remote On/Off connected to your PLC flow control switch will only have an effect on the pump when the “Press RUN When Ready” screen is displayed, or the pump is actually metering. This requires a contact closure (CC), i.e. a solenoid or solid-state switch. When the CC is closed, the VitaPump will run, when the CC is open, the pump will stop. All other commands must be entered from the Front Panel, or via a PC interface.

## Printer Documentation:

The VitaPump will output data to a printer or a PC at periodic intervals for archival purposes. The following is an example of that data, and an explanation of the abbreviations used. A slightly different form of PC output is available, see Section 5.2 PC Control, Commands & Data of the VitaPump manual for an example.

```
VITAMIN D = 6.00g/m: ALARMS: BW=2; PR=3; LIMIT:BW=0.000kg
T = 00.00; TW = 0.000kg; BW = 0.000kg; PR = 6.00g/m ST=START
T = 00.05; TW = 0.030kg; BW = 0.030kg; PR = 6.00g/m ST=RUN
T = 00.10; TW = 0.060kg; BW = 0.060kg; PR = 6.00g/m ST=RUN
T = 00.15; TW = 0.090kg; BW = 0.090kg; PR = 6.00g/m ST=RUN
T = 00.20; TW = 0.120kg; BW = 0.120kg; PR = 6.00g/m ST=STOP AL = PR
T = 00.21; TW = 0.120kg; BW = 0.120kg; PR = 6.00g/m ST=EXIT
```

VITAMIN D = Several different labels available to choose from under Mode:Setup, SET LABEL.

T = TIME: Relative time counter, starts/resets at beginning of batch metering program. Can be set to actual time, and print the current date in header. See example below.

TW = Total Weight, long term cumulative counter, can be reset in Mode:Setup, CLEAR TOTAL.

BW = Batch Weight, cumulative batch weight counter, resets at beginning of batch metering program, usually when new vitamin bottle is placed on balance.

PR = Pump Rate, gravimetric metering rate expressed in grams/minute

ST = STATUS, Pump Status (Start, Run, Pause, Run, Exit)

AL = ALARM, Print out of Alarm condition. AL=PR represents Pump Rate Alarm, AL=BW represents Batch Weight Alarm.

**NOTE:** Three alarm levels are defined and displayed in the program header of the printout as follows: 1 = Off (Deactivated); 2 = Alert (Metering continues, auditory beep/5V output to remote alarm occurs); 3 = Pump Stop (Stops the pump, auditory beep/5V output to remote alarm occurs). Immediate data printout occurs when RUN, STOP or EXIT keys are pressed, and when an alarm occurs. All other printouts occur at a user definable frequency in hours:minutes. (Mode:Setup, Printer, Time)

If you choose to do so, you can go to Mode:Setup, Clock and enter the Time of Day (24hr format), Day, Month, and Year. Under Mode:Setup, Clock, Print Enable, select Time of Day instead of Relative Time. The data printout will change to look like the following, and drastically ease your record keeping:

```
VITAMIN D = 6.00g/m: ALARMS: BW=2; PR=3; LIMIT:BW=0.000kg 10/29/02
T = 16:30; TW = 0.000kg; BW = 0.000kg; PR = 6.00g/m ST=START
T = 16:35; TW = 0.030kg; BW = 0.030kg; PR = 6.00g/m ST=RUN
T = 16:40; TW = 0.060kg; BW = 0.060kg; PR = 6.00g/m ST=RUN
T = 16:45; TW = 0.090kg; BW = 0.090kg; PR = 6.00g/m ST=RUN
T = 16:50; TW = 0.120kg; BW = 0.120kg; PR = 6.00g/m ST=STOP AL = PR
T = 16:51; TW = 0.120kg; BW = 0.120kg; PR = 6.00g/m ST=EXIT
```

The following chart shows tubing dimensions and the available flow rates based on tubing size, and the standard 160rpm motor:

	13	14	16	25	17	18
Tubing ID*: in	0.030	0.060	0.125	0.190	0.250	0.310
Tubing OD*: in	0.157	0.189	0.251	0.314	0.376	0.439
Tubing Wall*: in	0.063	0.063	0.063	0.063	0.063	0.063
Pump Rate Range*: gm/min	0.5 - 10	1.7 - 35.2	6.3 - 129	12.5 - 283	18.5 - 405	24.7 - 554
* Nominal Values						
<b>Pump Head Model:</b>	<b>TANDEM 1081</b>					

**Service Schedule:** SciLog recommends a factory cleaning, testing and recalibration be done to your Smart Pump ***at least once a year***, to maintain the accuracy of the unit and reduce your downtime. SciLog also has loaner units available you can rent if you need to keep production running while SciLog is performing maintenance on your pump. Call us at 800-955-1993 for an RGA and arrange for a loaner if needed. If you have a large number of units, call us, and we can design a preventative maintenance program specifically for your company.

**CAUTION:** The following information should be considered and passed along to the operators:

- 1) Changing the vitamin reservoir. DO NOT REPLACE THE VITAMIN BOTTLE WHILE THE PUMP IS RUNNING, IT WILL STOP!! Always press the EXIT button on the front panel, change the reservoir, press "A" to execute the program again, and press RUN when ready. The VitaPump will tare the scale, zero the batch weight, and resume normal operations. If you are changing the reservoir in response to a Pump Rate Alarm, the same procedure applies. You do not want to leave the pump running at 100% motor speed.
- 2) Remote On/Off. This is generally connected to your flow controller and can work in a steady state or pulse mode. Under Mode:Setup, Remote On/Off, if you select ENABLE, it requires a steady state closed or open switch. If DISABLE is chosen, a pulse type signal (like that generated by pressing and releasing a foot switch) is required. In either case, this only functions when the pump is metering, or is showing "Press Run When Ready" on the front panel.
- 3) SciLog suggests the use of #14 or 16 tubing, dependant upon your flow rates, and that you move the portion inside the pump 3-4 inches toward the discharge side of the pump periodically to avoid excessive wear.

Safety Information:

## **Be sure to read and observe the following requirements!**

Before connecting the **VitaPump**<sup>™</sup> to mains, make sure that the mains voltage corresponds to the voltage rating given on back panel of the pump.

Opening the **VitaPump**<sup>™</sup> cover exposes live parts. Therefore, the cover must not be removed. If repair should be required, return the pump to the factory.

If opening of the **VitaPump**<sup>™</sup> cover is inevitable, the pump must first be disconnected from all voltage sources.

Make sure that the mains plug has been pulled out.

Repair or adjustment of an opened **VitaPump**<sup>™</sup> under voltage must be carried out only by a skilled person who is aware of the hazard involved.

Whenever it is likely that the protection has been impaired, the **VitaPump**<sup>™</sup> must be made inoperative and secured against any unintended operation. The protection is likely to be impaired if, for example:

- The **VitaPump**<sup>™</sup> shows visible damage
- The **VitaPump**<sup>™</sup> fails to perform as intended
- After prolonged storage at temperature above 70°C
- After severe transport stresses

Before re-commissioning the **VitaPump**<sup>™</sup>, a professional routine test according to EN 61010-1 must be performed.

## Installation & Start-Up



***Installation*** of the VitaPump™ system must be carried out only by trained personnel in accordance with the relevant regulations and this operations manual.

Make sure that the technical specifications and input ratings of the VitaPump™ are observed. See “VitaPump™ Specifications”

The VitaPump™ must be connected to a properly grounded power supply receptacle.

The VitaPump™ location must not block access to the power disconnect point for the power supply.

The protection provided by this equipment may be impaired, if the VitaPump™ is used in a manner or for purposes not specified by the manufacturer, SciLog, Inc.



***Start-up*** of the VitaPump™ must be carried out only by trained personnel in accordance with the relevant regulations and this operations manual.

Before first start-up, a parameter setting procedure and/or a parameter review must be performed by supervisory personnel.

User selected parameters are stored in the VitaPump memory and are battery backed for approximately one (1) year. After longer power outages these data can be lost.

## Maintenance & Cleaning:



The **VitaPump**<sup>™</sup> is maintenance free. The pump head and associated pump tubing must be flushed with distilled water or isopropanol for at least 5 minutes prior to pump shutdown.



To remove dust, dirt and stains, the outer surfaces of the **VitaPump**<sup>™</sup> may be wiped using a soft, non-fluffing cloth moistened with water. If required, you may also use a mild detergent or 2-propanol.

## Standards:

The **VitaPump** meets the following generic standards:



- Safety Requirements: EN 61010-1: 1993
- Electromagnetic Emission: EN 50081-1: 1992
- Immunity to Interference: EN 50082-1: 1992

## Description of this Manual:

This operations manual provides following information:

- Safety Requirements
- Product Specifications
- Hardware
- Software



### **WARNING:**

**Warning means that ignoring the given instructions may lead to malfunction or damage of the instrument or other equipment and to personal injury.**



### NOTE:

Note calls your attention to important information. *Italics* are used to further emphasize certain information.

## Introduction:

The VitaPump™ is interfaced with an electronic balance to provide programmable vitamin feed by weight. Two user-definable alarms can be utilized to monitor pump rate and solution batch weight. All pump parameters and data can be printed out or sent to a PC for data archiving.

**Please read the following instructions carefully!**

**Inspections:** Unpack the **VitaPump™** and accessories carefully from the carton. Cross-check the contents against your purchase order to verify that all parts are included and undamaged.

Please do the inspection now, even if the **VitaPump™** is not used immediately. Many carriers must receive damage claims within seven days of delivery. Please retain all packing material so the unit may be shipped safely, if necessary.

**SciLog Customer Service:** If you need assistance, please call:

**1-800-955-1993**

SciLog Customer Service personnel will be able to serve you more efficiently if you have the following information:

- Serial number (back panel) and model name of the equipment.
- Installation procedure you used.
- Concise list of symptoms.
- List of operating procedures and conditions you were using when problem arose.

**Warranty Repair:** Units covered under warranty will be repaired and returned to you at no charge. If you have any questions about applicability, please contact SciLog.

**Non-warranty Repair:** For out-of-warranty repair, contact the SciLog Customer Service Department. A SciLog representative will discuss service options with you and can assist in making arrangements to return the equipment, if necessary.

**Return Procedure:** Before returning any SciLog equipment, contact SciLog to obtain a Return Goods Authorization (RGA) Number. Equipment will not be accepted unless an RGA # has been issued by SciLog.

**Return Procedure Continued:**

To return a piece of equipment:

- Carefully pack the unit to prevent damage in transit. Check with SciLog regarding the proper method of shipment. No responsibility is assumed by SciLog for damage caused by improperly packaged instruments. Indicate the RGA Number on the carton and on the packing slip.
- Always insure for the replacement value of the unit.
- Include a description of the symptoms, your name, return address, phone number, RGA number and purchase order to cover repair costs, return and shipping charges, if your institution requires it. Ship to:

SciLog Inc.  
8845 S Greenvue Dr #4  
Middleton, WI 53562-2562

**Limited Warranty:** SciLog warrants instruments or equipment manufactured by SciLog for a period of one year from the date of shipment, against defects in material and workmanship under normal use and service (as described in the operations manual which accompanies such equipment). This warranty will be voided in the event the equipment is altered or modified by, or at the direction of, anyone other than SciLog personnel. Any defect covered by this warranty shall be corrected by replacing or repairing, at SciLog's option, parts determined by SciLog to be defective.

The foregoing warranty is exclusive of all other warranties, whether expressed or implied, including any warranties of merchantability and any warranties of fitness for purpose, but without limitations thereto, are expressly excluded.

Pump heads are expressly excluded from the SciLog warranty. Check with the original pump head manufacturer for their return policy.

Under no circumstances shall SciLog be liable for any consequential damages, or any direct or incidental damages, arising out of any breach of any expressed or implied warranty or otherwise, except only in the case of personal injury where applicable law requires such liability.

Carefully package returned instruments to prevent damage and insure them against possible damage or loss. SciLog will not be responsible for damage that results from careless packing. This warranty is not assignable.

# VitaPump™ Specifications: *Summary*

## Mechanical:

**Dimensions:** 5.75" (14.6 cm) W x 8.5" (21.6 cm) H x 11"(27.9 cm)D

**Weight:** 14 lbs (6.4 kg).

**Enclosure:** Aluminum / Steel; Corrosion Resistant, Recessed Handle.

**Pump:** Accommodates peristaltic pump head, TANDEM™ model 1081, with a 160RPM motor. Uses Masterflex® tubing sizes: #13, 14, 16, 25 & 17. Magnetic Gear (Micropump) and Piston (FMI) models are also available.

## Electrical:

**Power:** 110-120 / 220-240 VAC, 60 / 50 Hz, 75 Watts; double fused, Fuse Rating: TIAL 250V (CE: IR35A, 250VAC)

**Motor:** Variable speed, 160 RPM (nominal) motor; RPM maximum at 24 VDC, 3.0 Amps; optically encoded, servo - controlled.

**Operating Range:** 4 to 40° C, 100% Humidity.

**Motor Encoder:** 120 lines per motor revolution.

## I/O Ports:

1. First serial port labeled "**Balance**", Male DB9 connector; connects to Ohaus, Mettler, and Sartorius Balances and Scales.
2. Second serial port labeled "**Printer,**" Female DB9 connector; connects to SciLog Printer or user PC.
3. Phone jack connector labeled "**Foot Switch**" for remote "RUN" / "STOP" control of VitaPump via foot switch.
4. DB15 labeled "**Valve V**". *Not used in vitamin metering applications*
5. DB37 labeled "**External I/O**" is used for **alarm output** (5.0 VDC, two-wire connection between pin 8 and pin 16). **Remote "RUN" / "STOP" control input.** Use a contact closure (i.e.solenoid switch) for remote control of VitaPump (two-wire connection between pin 19 and pin 37, ground)

**Display:** Two line LCD, 20 characters each line, back-lit.

**Data Entry:** Membrane keyboard with auditory feedback.

## Software:

- Main menu with the following three (3) operational modes.
- Metering Mode: Gravimetric vitamin metering, requires electronic balance. Several "Labels" available. (i.e. "Vitamin A & D", "Vitamin A" , etc.) Two user-definable alarms.
- Setup Mode: Selection of user preferences and interface options.
- Manual Mode: Simple pump control (% Speed); no alarms.

# Part A: Hardware

## 1.0 VitaPump™: Overview

The **VitaPump** provides high precision, high accuracy, programmable metering capability. The VitaPump utilizes an optically encoded, servo-controlled motor, ensuring a highly reproducible pump performance. The VitaPump comes with the TANDEM™ peristaltic pump head (TANDEM Model 1081), which is powered by a 160 rpm motor.

### 1.1 PumpSense™: Pump Overload Protection

**When the installed pump head requires excessive torque because of pump tube failure or “freezing” of the pump head, the VitaPump software will recognize this condition and go into a stand-by mode. The pump motor is turned off and the following message is displayed:**

**CHECK YOUR PUMP HEAD**  
**Press Any Key**

Before continuing with your pumping application, remove the defective pump head and either clean the pump head or replace with a functional pump head. The PumpSense™ feature has been implemented as a failsafe device to protect your pump head and motor control circuit from permanent damage.

**NOTE:** Call SciLog Customer Service at 800-955-1993 to arrange for service if the “Check Your Pump Head” message does not disappear after the above suggested measures have been taken.

Pump tubing can become frayed when overused. When this happens, the pump tubing tends to wind itself around the pump rotor: ***To avoid this problem, check your pump tubing at regular intervals, move the used tube section 3-4 inches to the pump discharge side.*** Use only high quality, correctly sized pump tubing.

### 1.2 Pump Head/Motor:

The **VitaPump**™ comes with a 160 rpm, optically encoded, servo-controlled motor and a TANDEM™ Dual Channel Peristaltic Pump Head. Materials of Construction: Stainless Steel and Noryl high impact resistant plastic, four (4) roller design (stainless steel). Passive pump tube retention, two stainless steel forks automatically engage pump tubing when the TANDEM pump head is closed. The TANDEM Model 1081 (P/N: 080-1081) is compatible with thin-walled (0.062”) Masterflex® pump tube sizes 13, 14, 16, 25, 17 & 18.

If you have a system with backpressure in excess of 30 psi, the **VitaPump**™ is available with an FMI Q Sanitary Piston Pump. This pump head will handle up to 100 psi, and is constructed of 316 SS and Ceramic parts. It handles similar flow rates to the Tandem 1081 head, and is equipped for ¼” ID tubing.

## 2.0 Front Panel:

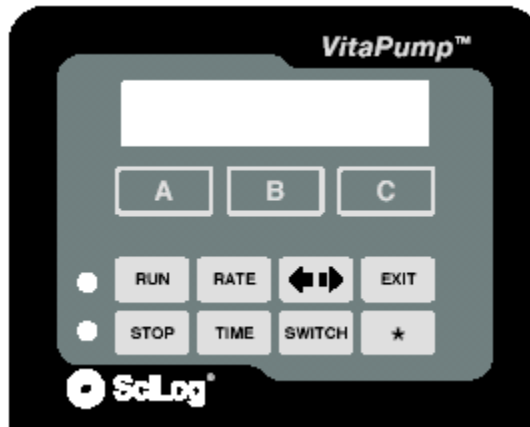

The front panel consists of a user interface that includes an alphanumeric display and a membrane keypad to select operational modes and alarm settings. The display is a two line, 20 characters each, liquid crystal display (LCD). The display is backlit to allow easy viewing over a wide range of lighting conditions.

The lower line on the LCD is used to signify the function of the “soft keys” marked “A”, “B” and “C”. The “soft key” current labels are displayed in the lower line of the LCD. If you press these keys, then the function displayed above it will be performed.

In the vitamin-metering mode, use EXEC (key “A”) for executing the metering mode, use the EDIT (key “B”) for editing the metering parameters and use ALARM (key “C”) for setting alarm parameters.

Four front panel keys are frequently used: Pressing the “RUN” key will start the vitamin-metering, while pressing the “STOP” key will interrupt the pump action. The “RATE” key allows you to change the vitamin metering rate, while the double-arrow key allows changing pump direction. The “EXIT” key will stop the pump, *reset the batch weight counter (BW)*, and place the **VitaPump** into a stand-by condition while showing the following display:

- VITAMIN D -		
Exec	Edit	Alarm

The “RUN” and “STOP” functions can also be remotely controlled via a two-conductor cable connected to pin 19 and pin 37 of the DB37 “External I/O” port.

Note: The “TIME”, “SWITCH” and “ \* ” keys are not active in the vitamin metering modes.

## 3.0 Back Panel:

**3.1 Printer Port:** The SciLog printer (P/N: 080-095) is connected to the **VitaPump** via Serial Port 2 labeled “**Printer**”. You need a printer cable (P/N: 080-096) to make the connection; the other end of printer cable terminates in a connector that interfaces with the printer.

**3.2 PC to Pump Connection:** If you wish to connect the **VitaPump** directly to your PC, you need a PC cable (P/N: 080-073) to make the connection between the COM port on your PC and the “**Printer**” port on the VitaPump.

**3.3 Balance Port:** The Serial Port 1 is labeled as “**Balance**” allows you to interface with a variety of top-loading balances from Ohaus, Mettler and Sartorius. A special balance cable is required for interfacing with the balance. The **VitaPump** will automatically implement the correct parameters for communicating with the balance selected in Mode: Setup, Balance. Check that the proper communications parameters are also implemented in the balance you are using. If you purchased the VitaPump and balance from SciLog as a system, everything will be configured for you already.

**3.4 Foot Switch Port:** Interfaces with SciLog foot switch (P/N: 080-059) and allows remote Start / Stop control of the VitaPump. This connector is fragile, and its use for this application is not recommended, see “**External I/O**” port, listed below

**3.5 External I /O Port:** A TTL alarm *output* (two-wire cable between pin 8 and pin 16) allows you to monitor VitaPump alarm conditions (5.0VDC output control signal).

An additional TTL *output* will provide you with a similar signal to provide a Status Signal that is On when the VitaPump’s motor runs, and Off when it isn’t. (two-wire cable between pins 12 & 31)

A TTL *input* (two-wire cable between pin 19 and pin37) allows remote “RUN” / “STOP” by means of a contact closure. This last feature can be set for either a pulse (footswitch) or level (contact closure) signal input.

All three cables are usually assembled and tested at SciLog prior to shipment.



# Part B: Software

## 1.0 Main Menu

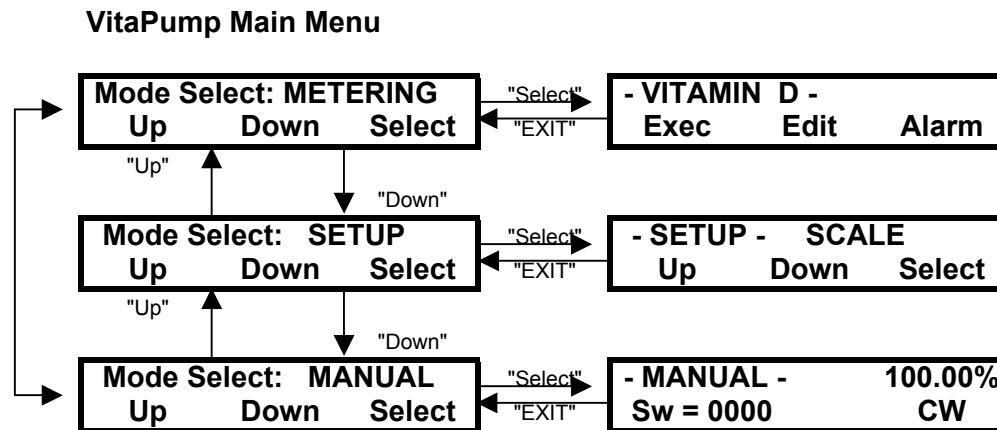

On power-up the VitaPump will perform a scale initialization to confirm that the balance is properly connected and responding to the VitaPump. The power-up-display will prompt you to press the “RUN” key to start vitamin metering using the last metering rate set.

If instead, you press the “EXIT” key twice, you will reach the Main Menu above. The Main Menu consists of three (3) operational modes: **METERING**, **SETUP**, and **MANUAL**. You can use the “Up” and “Down” keys to scroll through the menu. Press the “Select” key to enter the first sub level menu, and the “Exit” key again to return to the previous level.

**METERING** Mode allows you to set the Pump Rate and Direction, as well as configure both the Pump Rate Alarm and the Batch Weight Alarm.

**SETUP** Mode is used to configure the Scale, Clock, Printer, Pump, Serial Mode, External Run-Stop, Set Label, and Clear Total parameters.

**MANUAL** Mode allows the VitaPump to be operated manually. You can select pump speeds from 0 – 100% of motor speed. In Manual Mode, gravimetric (with a balance) metering is not possible.

## 2.0 Vitamin Metering: Edit / Alarm

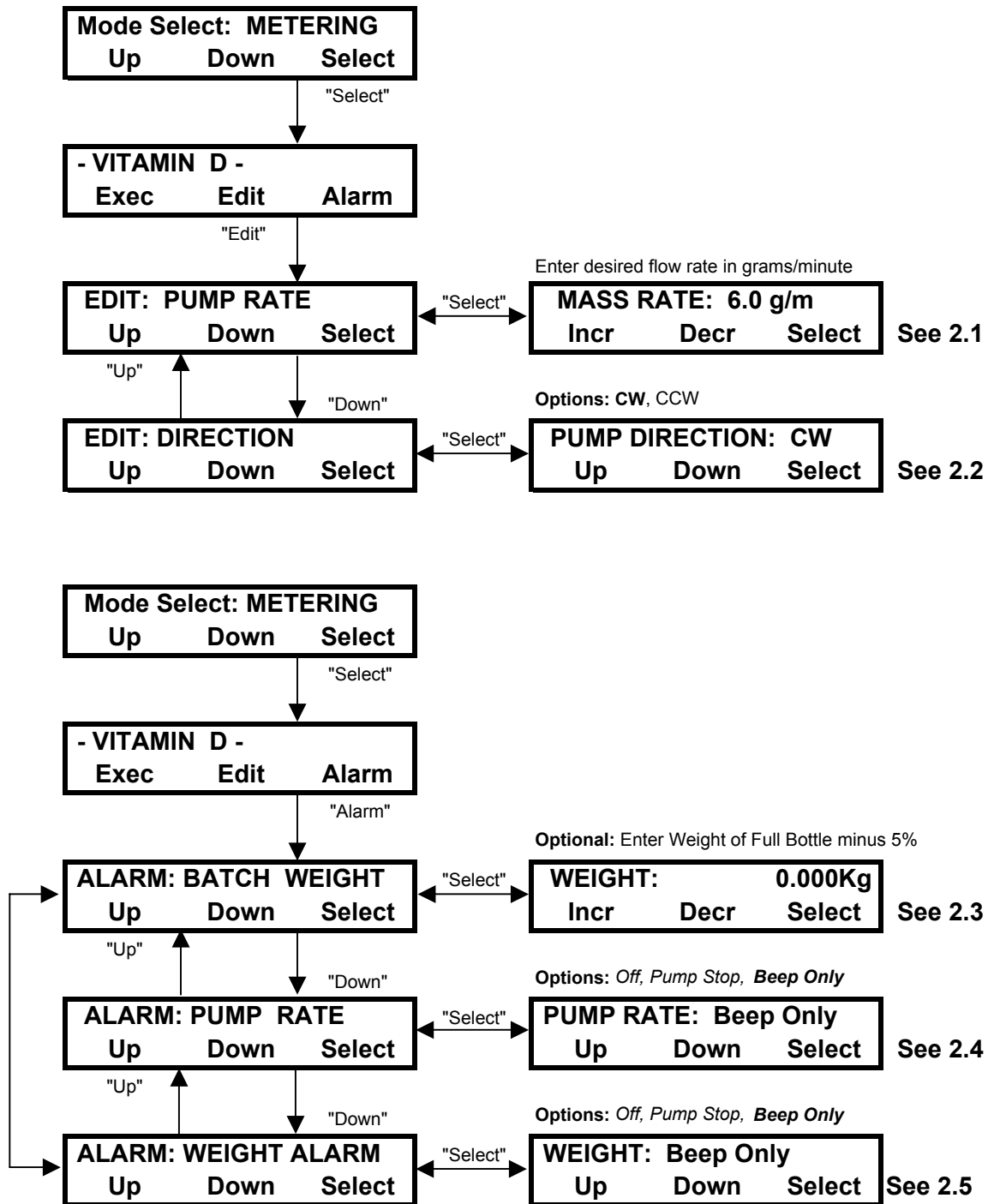

## 2.0 Vitamin Metering: *Edit / Alarms*

The Edit Sub mode allows you to set the vitamin-metering rate and the pump direction. Do not set a rate that exceeds the capabilities of the motor/pump head/tubing combination. VitaPumps come with a 160-rpm motor and either a Tandem 1081 peristaltic pump head for thin walled tubing, or an FMI Q1 Sanitary head. Most dairies use the Tandem 1081 with thin walled tubing. This has a flow range of 0.5 – 554 gm/min depending on the size of tubing used, and will handle up to 30 psi of backpressure. Please refer to the flow rate chart in Appendix “A”. For those facilities pumping against higher backpressures, an FMI Q1 Sanitary piston pump head is used. This head has a flow range of 0.54 – 42.7 gm/min at up to 100 psi of backpressure. Setting a metering rate higher than the pump can deliver will trigger the Pump Rate Alarm.

**2.1 Pump Rate:** Use the “Incr” and “Decr” keys to set the metering rate in grams / minute.

**2.2 Pump Direction:** Use the “Up” and “Down” keys to choose between CW (Clockwise) and CCW (Counterclockwise). Always use CW when using a Q1 Piston Head.

The Alarm sub mode is used to configure the Pump Rate and Batch Weight Alarms. All alarms have 3 options: **OFF** (disabled), **BEEP ONLY** (Audible Alarm), and **PUMP STOP** (Stops the pump, and provides Audible Alarm). The VitaPump is equipped with a Remote Alarm feature that will provide a 5VDC signal to a klaxon or other PLC controlled device.

**2.3 Batch Weight:** Used in conjunction with Weight Alarm (2.5 below) to alert the operator that the vitamin bottle is nearly empty. Usually set to weight of full bottle minus 5%.

**2.4 Pump Rate:** The Pump Rate alarm is triggered when the VitaPump is unable to maintain the metering rate for any one-minute period. The motor will speed up in an attempt to maintain the rate, and continue until it has reached 100% of motor speed. If configured to do so, it will stop the pump and sound an audible alarm. **Options: OFF, Beep Only, and Pump Stop.** This is normally a critical alarm, and should be set to **PUMP STOP**.

**2.5 Weight Alarm:** Used in conjunction with Batch Weight above to alert operator of nearly empty vitamin bottle. **Options: OFF, Beep Only, and Pump Stop. Default is Beep Only.**

### 3.0. Metering: Exec

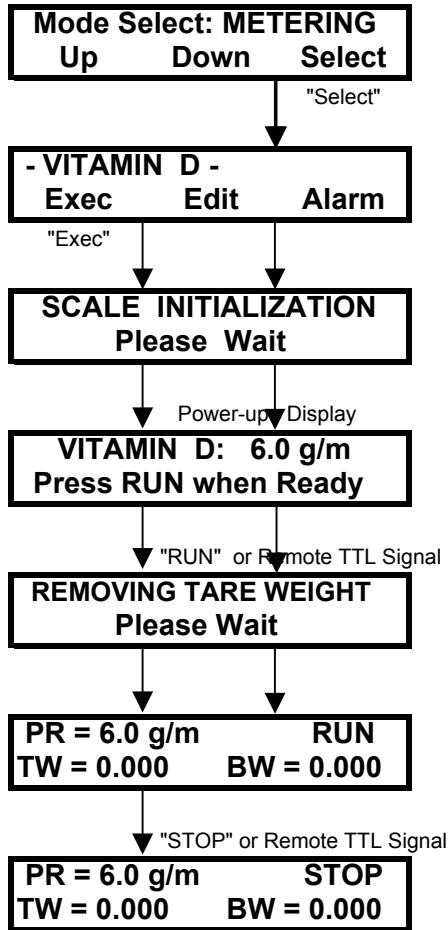

On the VitaPump front panel, the "RATE" key is a shortcut key you can use for changing the vitamin pump rate while the pump is running.

***Do not remove or replace the vitamin bottle while the VitaPump is metering. it will see this as a drastic weight change and stop!*** Press the Exit key, replace the bottle, press the Exec and then RUN keys to restart the metering. The VitaPump will automatically tare the balance and reset the Batch Weight.

When a Pump Rate Alarm occurs, you must press exit, correct the situation that caused the alarm, and then press Exec. Just pressing Run will leave the pump at 100%, and that is not desirable.

**PR = PUMP RATE**  
**TW = TOTAL WEIGHT**  
**BW = BATCH WEIGHT**

The BATCH WEIGHT counter is reset when the Exec and RUN keys are pressed to start the metering.

The TOTAL WEIGHT counter is a longterm vitamin-usage counter that can only be reset in **SETUP-CLEAR TOTAL**



## 4.0 Setup: Edit

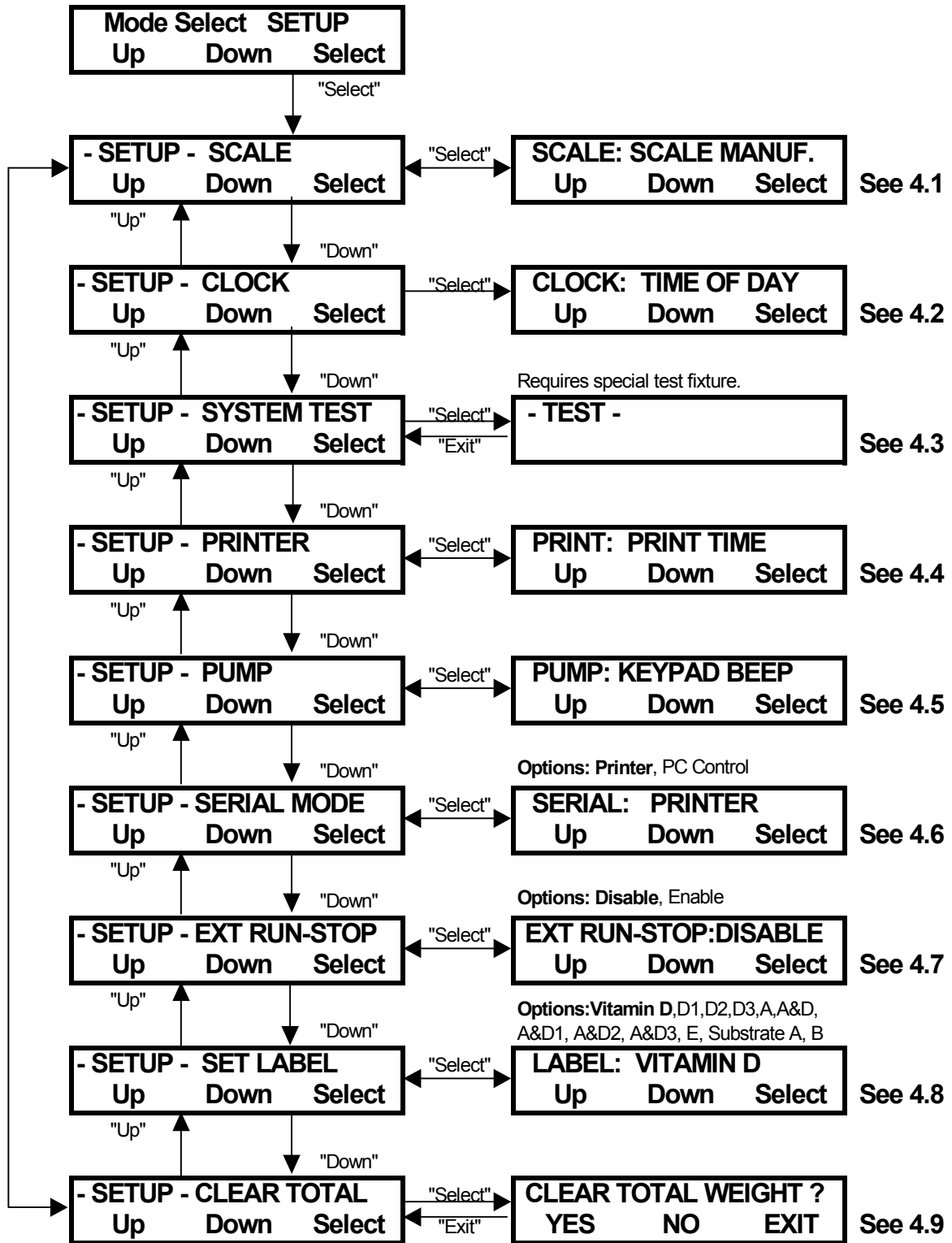

## 4.0 SETUP: Edit

**Summary:** The Setup menu consists of nine (9) entries. In 4.1 **Setup: Scale**, you select from five (5) different manufacturer of electronic balances: Sartorius, Mettler, Ohaus, Ohaus 2 and Toledo. However, only certain models with serial communications capability can be accommodated. By choosing the scale manufacturer the VitaPump automatically selects and implements the correct communications protocol. In 4.2 **Setup: Clock** allows setting of Day, Month, Year, and Time in 24 hr military format. In 4.3 **Setup: System Test** you can diagnose the electronic outputs of the VitaPump. In 4.4 **Setup: Printer**, the communications parameters for hooking up to a SciLog printer (Cable: P/N: 080-095) or a PC (RS-232 Cable for Serial Port 2: P/N: 080-073) are selected. In 4.5 **Setup: Pump** certain user-preferences can be selected, whereas the 4.6 **Setup: Serial** allows you to choose between Printer output and PC Control of the VitaPump. In 4.7 **Setup: Ext Run-Stop** you can enable or disable an external control signal like that provided by a PLC. 4.8 **Setup: Set Label** allows you to select the appropriate Vitamin Label used in the header of the print out. 4.9 **Setup: Clear Total** allows for clearing of a long-term counter showing Total Weight.

**4.1 Setup: Scale** The following electronic scales can be accommodated by the VitaPump: Mettler PM, PGS, Panther, Lynx and SpeedWeigh Series balances, Ohaus GT Series, GT "Precision Advanced" models (Ohaus) as well as the Ohaus "Explorer" and "Navigator Series. The Ohaus High Capacity "IP" Series can be used when the "Ohaus2" parameter is selected and the Sartorius MC-1 Series can be interfaced when "Sartorius" is selected. Also see following pages for setting communications parameters in the various balances.

**4.2 Setup: Clock** Used to set Day, Month, Year and Time. Time is in 24 hr military format. Print Enable allows choice between actual time and relative time output.

**4.3 Setup: System Test.** Allows you to diagnose the outputs of the VitaPump; requires you to connect a set of test jumpers (P/N 080-058) into the DB37 labeled "I/O" port for testing.

**4.4 Setup: Printer:** Select parameters for SciLog printer (P/N 080-095) or PC. Default settings are for the printer, select Print Time, user-defined, as small as every 10 seconds, max 30 min. Baud Rate 9600, Stop Bits 2, Parity None, Word Length 8, Print Delay = 4 sec. for printer, Print Delay = 0 sec. for PC.

**4.5 Setup: Pump** Select the following user preferences: Keypad Beep (On/Off), Switch Configuration (Level / Pulse), Switch Polarity (Normal/Inverted), Motor Start (Hard / Soft-Ramp), Power Up (Mode/Menu/Run), LCD Adjust (Display Contrast Adjust), ASCII Feedback (On / Off, motor encoder data available at Serial Port 1 labeled "Balance", need RS-232 cable (P/N 080-050). Factory Reset: (Resets all variable pump parameters to their original, factory defaults). TTL1 ON/OFF (Yes / No).

**4.6 Setup: Serial Mode** Select between Printer or PC Control. Effects output of VitaPump as well as control protocols for PC interface. See Section 5.0 for details.

**4.7 Setup: Ext Run-Stop** Select between Enabled and Disabled. When enabled, allows remote contact closure control of VitaPump. Functions from "Press RUN when Ready" screen, and while VitaPump is metering. When Disabled, behaves as a Footswitch input using a Pulse signal for the Remote Run-Stop.

**4.8 Setup: Set Label** Select appropriate Label for printout for Vitamin being pumped. Choose from a variety of different labels.

**4.9 Setup: Clear Total** Clears long-term counter that displays Total Weight (TW) of vitamins dispensed since last cleared. Not reset by turning off pump or tarring of balance when bottles are changed.

## 4.10 Setup: Scale

### 4.11 Mettler - Toledo Balance Parameters:

#### 4.111 Models PG-S (1997), i.e. PG5002-S

Hardware Requirement: 1. SciLog PGS Balance Cable (P/N: 080-067PGS) 2. Order Mettler PGS Balance with RS232C Interface. **NOTE** :Delta range balances cannot be accommodated

Select the following parameters in the PGS Mettler Balance “MENU”, all other balance parameters are at their factory settings.

4.4	Selection of the Calibration:	<b>CAL int</b>
4.7	Vibration Adapter	<b>2</b>
4.8	Process Adapter	<b>2</b>
4.9	Repeatability:	<b>Good</b>
4.12	Auto Zero Switched OFF	<b>no AZero</b>
4.13	No Automatic Shutdown:	<b>A.oFF</b>
4.17	Baud Rate:	<b>bd 9600</b>
4.18	Setting Parity/Bit:	<b>8b-no</b>
4.19	Setting Handshake:	<b>HS Hard</b>

Note: Verify that all the above parameters have been entered and accepted by the balance. In the VitaPump Setup mode, select SCALE, then select “Mettler”. Connect the SciLog balance cable P/N: 080-067PGS.

#### 4.112 PM Series Mettler Balances, i.e. PM 3000, PM 6000, etc.

Consult your Mettler manual, enter the following parameters into the Mettler balance using the “I-Face” menu:

**S = All**  
**Baud Rate = 9600**  
**P = N** (Parity = None)  
**Pause = 0**  
**Au = Off**

**Weighing Process Adapter:** (Droplet Symbol) should be set to “Universal”, i.e. standard setting, second largest droplet symbol.

**Vibration Adapter:** (Wave Symbol) should be set to “unstable”, i.e. largest wave symbol.

NOTE: Delta range balances cannot be accommodated.

Note: Verify that all the above parameters have been entered and accepted by the balance. In the VitaPump Setup mode, select SCALE, then select “Mettler”. Connect the Mettler balance cable P/N: 080-067

#### 4.113 Mettler Panther & SpeedWeigh Scales

You must first access the switch SW1 (see Mettler Technical Manual: Terminal Main PCB”) and turn it to the “ON” position in order to enter the scale SETUP menu. Press “Zero” and

“Enter” keys simultaneously to get access to the scale Setup Menu. Use the “ENTER” key to step through the menu. First, make sure that all parameters are in their factory default settings, then make the following changes to the default settings:

- F1.2** Enter weight units: “1” for lb “2” for kg., or “3” for grams. Select “3” when interfacing with the VitaPump.
- F1.3** Enter scale capacity for which you want to calibrate the scale. For example, select 2000gr. if you wish to display and control in grams and have a scale capacity of 2000 gr .
- F1.4** Select scale increment size, this value is dependent on the entered scale capacity, for 2000gr the smallest scale increment size is 0.2gr. For optimal pump control, always select the smallest available scale increment size. NOTE: at this point you may want to calibrate the scale with a known weight, set CAL = 1.
- F3.2** Enter “2” for SICS Protocol, this will set up the appropriate communications protocol in the Mettler scale.
- F4.1** Enter “0”, disables discrete input function.
- F5.1** Enter “1”, if scale is a Mettler “Speedweigh”, i.e. Model SW 15000

All other scale parameters should be at their factory default settings. In the VitaPump (SETUP: Scale) select “**Mettler 2**” as scale manufacturer, by selecting “Mettler 2” you are implementing the appropriate communications protocol that enables the VitaPump to “talk” with your Mettler scale.

**Scale RS-232 Connection:** In addition to selecting the appropriate parameters in your scale as well as in the VitaPump, you must make the correct cable connections (P/N: 780-066) between your and the VitaPump. Open the scale terminal enclosure and identify the TB2 terminal block at the bottom of the scale Terminal Main PCB, which constitutes the RS-232 Interface. The 9-pin TB2 header is labeled “TBS RS232/TTL”. Make the following connections at the TB2 connector:

Scale / TB2	Wire/Color	VitaPump/ DB9 Connector
(Labeled “TB2 RS232/TTL”)		
2 (RxD)	White	2
1 (TxD)	Black	3
3 (GND)	Red	5
1&5 Jumper		

#### 4.114 Mettler Viper PM, PB Models

To enter the Technical Setup mode, press and hold the “Print” key until the word **CODE** appears on the display. Then press “Zero”, “Tare”, “Zero”, “Tare”, “Print”, and the word **SCALE** will appear. You are at the top of the menu. Use the “Zero” and “Tare” buttons to scroll thru choices on a level, and the “Print” button to select.

Menu Level 1	Level 2	Level 3 Selected Menu Item
<b>SCALE</b>	1.1 Serial Number (snr)	
	1.2 Metrology(metrolo)	
	<b>1.3 Build</b>	<b>Unit</b> <b>g (grams)</b>
	1.4 Linearity (linear)	<b>Resolution</b> <b>0.1g</b>
	1.5 Geo Value (geo)	
	1.6 Calibration (cal)	
	<b>1.8 Units</b>	<b>Displayed</b> <b>g (grams)</b>
	1.9 Tare	
	1.10 Zero	

1.11 Filtering (filter)

1.12 Sreset?

```
TERMINAL
COMMUNICATION      Mode           Output           SICS
(comm)              Parameters (params) Control
CReset ?
DIAGNOSTICS (diagnos)
END
```

**NOTE:** The **Bold** parameters are the only custom settings needed for communication with the VitaPump. All others should remain at factory defaults. If you are uncertain as to which parameters have been implemented in your scale, review all parameter settings by stepping through the scale menu. Alternatively, carry out a parameter reset by pressing the ‘print’ key at the ‘Sreset?’ or ‘Creset?’ in the BUILD and COMM Menus, then add all custom parameters outlined in Bold. The scale parameters outlined above insure that the Viper scale is capable of communicating with the VitaPump. Consult your scale manual for help navigating through the scale menu.

In the VitaPump Setup Mode, select “**METLER**”, see **SETUP: SCALE: MANUF**. By making this selection, the VitaPump will implement the correct parameters for communicating with the Viper scale. You will also need SciLog P/N 080-067PGS Mettler PGS Balance-Pump Interface Cable.

#### 4.12 Ohaus Balance Parameters:

##### 11.121 Older Models ( before 1988) GT 2100; GT 4100:

**NOTE:** You need a SciLog RS-232 interface cable (P/N: 080-066)  
Select the following parameters from the Ohaus **Setup Menu**:

**A.L. = 0** , Selectable Integration.

**Stb. = 0** , Stability Level.

**A.t. = off**, Auto-Zero Tracking

Select the following parameters from the Ohaus **Print Menu**:

**Select RS-232 sub-mode;**

**br. = 9600**, Baud Rate

**Fr. = 0, Frame 0:** 7 Data Bits, 2 Stop Bits, No Parity.

**NOTE:** In the SciLog pump SETUP mode, select SCALE, then select OHAUS. Connect the SciLog RS-232 cable (080-066) marked “Ohaus” to the balance. The VitaPump will now be able to communicate with the Ohaus balance.

#### 4.122 Newer Ohaus Models “Precision *Advanced*”: GT Series

NOTE: You need a SciLog RS-232 interface cable (080-066)

Select the following parameters from the Ohaus **User Menu**:

**A.L = 1** , Averaging Level  
**Stb. = 1d**, Stability Range  
**Auto-O = off**, Auto-zero function turned off.

Select the following parameters from the Ohaus **Print Menu**:

**Select COM Sub-mode:**  
**bAud = 9600**, Baud Rate  
**dAtA = 7**, Data Bits  
**PARity = none**, Parity  
**StOP = 2**, Stop Bits

NOTE: Verify that all of the above parameters have been entered and accepted by the balance. In the SciLog pump SETUP mode, select SCALE, then select OHAUS. Connect the SciLog RS-232 cable (P/N:080-066) marked “Ohaus” to the balance. The VitaPump will now be able to communicate with the Ohaus balance.

#### 4.123 “Explorer” & “Voyager” Series Ohaus Balances:

NOTE: You need a SciLog RS-232 interface cable (P/N: 080-066). Delta range balances with movable Fine Range™ cannot be accommodated.

Select the following parameters from the Ohaus **Setup Menu**: Press the Ohaus Balance “SETUP” button at the front panel. From the “READOUT” menu select the following parameters:

**Filter: 2**  
**Stable: 1d**  
**Auto O: Off**

From the “RS-232” menu select the following parameters:

**Baud: 9600**  
**Parity: None**  
**Data: 7**  
**Stop: 2**

NOTE: Verify that all of above parameters have been entered and accepted by the balance. In the SciLog pump SETUP mode, select SCALE, then select OHAUS. Connect the SciLog Balance RS-232 cable (P/N 080-066) marked “Ohaus” to the balance. The VitaPump is now able to communicate with the Ohaus balance.

#### 4.124 “IP Series” Ohaus High Capacity: Models IP12KS & IP15KS

NOTE: Select “Ohaus 2” in the VitaPump Setup Scale mode. You also need a SciLog RS-232 interface cable (P/N: 080-067)

Select the following parameters from the Ohaus **Setup Menu**:

Enter the main menu of the IP balance and select “USER”. From the “USER” sub-menu, select the following parameters:

**Stability:** STB = .5  
**Averaging:** AL = 1

Enter the main menu of the IP balance and select “CONF”. From the “CONF.” sub-menu, select the following parameters:

**Baud:** 9600  
**Parity:** None  
**Handshake:** HS  
**Print Key:** Off  
**Number:** Off

NOTE: Verify that all of above parameters have been entered and accepted by the balance. In the SciLog pump SETUP mode, select SCALE, then select Ohaus 2. Connect the IP Balance RS-232 (P/N: 080-067) cable to the VitaPump. The VitaPump is now able to communicate with the Ohaus IP balance.

### 4.13 Sartorius Balance Parameters:

#### 4.131 Sartorius MC-1 Series (older models) and LC-1 Series (newer model)

NOTE: You need a SciLog RS-232 cable (P/N: 080-068) to interface with the Sartorius MC-1 Series balances.

Consult your Sartorius manual; enter the following protocol into the Sartorius scale:

**611 Print w/o stability**  
**822 Beep off**

All other communications parameters of the Sartorius balance are at their factory settings.

## 4.4 Printer Documentation:

The VitaPump will output data to a printer or a PC at periodic intervals for archival purposes. The following is an example of that data, and an explanation of the abbreviations used.

```
VITAMIN D = 6.00g/m: ALARMS: BW=2; PR=3; LIMIT:BW=0.000kg
T = 00.00; TW = 0.000kg; BW = 0.000kg; PR = 6.00g/m ST=START
T = 00.05; TW = 0.030kg; BW = 0.030kg; PR = 6.00g/m ST=RUN
T = 00.10; TW = 0.060kg; BW = 0.060kg; PR = 6.00g/m ST=RUN
T = 00.15; TW = 0.090kg; BW = 0.090kg; PR = 6.00g/m ST=RUN
T = 00.20; TW = 0.120kg; BW = 0.120kg; PR = 6.00g/m ST=STOP AL = PR
T = 00.21; TW = 0.120kg; BW = 0.120kg; PR = 6.00g/m ST=EXIT
```

VITAMIN D = Several different labels available to choose from under Mode:Setup, SET LABEL.  
T = TIME: Relative time counter, starts/resets at beginning of batch metering program. Can be set to actual time, and print the current date in header. See example below.  
TW = Total Weight, long term cumulative counter, can be reset in Mode:Setup, CLEAR TOTAL.  
BW = Batch Weight, cumulative batch weight counter, resets at beginning of batch metering program, usually when new vitamin bottle is placed on balance.  
PR = Pump Rate, gravimetric metering rate expressed in grams/minute  
ST = STATUS, Pump Status (Start, Run, Pause, Run, Exit)  
AL = ALARM, Print out of Alarm condition. AL=PR represents Pump Rate Alarm, AL=BW represents Batch Weight Alarm.

**NOTE:** Three alarm levels are defined and displayed in the program header of the printout as follows: 1 = **Off** (Deactivated); 2 = **Alert** (Metering continues, auditory beep/5V output to remote alarm occurs); 3 = **Pump Stop** (Stops the pump, auditory beep/5V output to remote alarm occurs). Immediate data printout occurs when RUN, STOP or EXIT keys are pressed, and when an alarm occurs. All other printouts occur at a user definable frequency in minutes:seconds. (Mode: Setup, Printer, Time)

If you choose to do so, you can go to Mode: Setup, Clock and enter the Time of Day (24hr format), Day, Month, and Year. Under Mode: Setup, Clock, Print Enable, select Time of Day instead of Relative Time. The data printout will change to look like the following, and drastically ease your record keeping:

```
VITAMIN D = 6.00g/m: ALARMS: BW=2; PR=3; LIMIT:BW=0.000kg 10/29/02
T = 16:30; TW = 0.000kg; BW = 0.000kg; PR = 6.00g/m ST=START
T = 16:35; TW = 0.030kg; BW = 0.030kg; PR = 6.00g/m ST=RUN
T = 16:40; TW = 0.060kg; BW = 0.060kg; PR = 6.00g/m ST=RUN
T = 16:45; TW = 0.090kg; BW = 0.090kg; PR = 6.00g/m ST=RUN
T = 16:50; TW = 0.120kg; BW = 0.120kg; PR = 6.00g/m ST=STOP AL = PR
T = 16:51; TW = 0.120kg; BW = 0.120kg; PR = 6.00g/m ST=EXIT
```

## 4.7 Setup: External Run/Stop

An interface cable set for the External Run/Stop, Status Signal and Remote Alarm Signal features (P/N 080-074) is available to connect the VitaPump to your process controller.

When the “**EXT RUN-STOP**” function has been “**Enabled**”, the VitaPump can be remotely controlled by a solenoid switch or contact closure. Fasten the “Remote Stop/Run” cable to the 37-pin VitaPump I/O port; connect the other end of the 2-wire cable to the “Common” and the “Normally Open” positions of the solenoid switch. When the solenoid switch is energized, the VitaPump will start metering Vitamin solution. Conversely, when the switch is open, the pump will stop (pause).

However, before remotely activating the VitaPump, make sure the balance has been turned on and the Balance Interface cable has been connected to the VitaPump “Balance” port. In addition, the VitaPump display should show the following:

<b>Mode Select: METERING</b>		
<b>Up</b>	<b>Down</b>	<b>Select</b>
Press "Select"		

<b>- VITAMIN D -</b>		
<b>Exec</b>	<b>Edit</b>	<b>Alarm</b>
Press "Exec"		

<b>SCALE INITIALIZATION</b>		
<b>Please Wait</b>		

<b>VITAMIN D: 6.0 g/m</b>		
<b>Press RUN when Ready</b>		

Energize the solenoid switch when the “Press RUN when Ready” display is shown. The energized solenoid switch will close the connection between the “Common” and “Normally Open” which provides the signal for the VitaPump to start metering. The VitaPump will stop metering when the solenoid switch is de-energized.

When the EXT RUN/STOP function has been “**Disabled**” in the SETUP mode, the “Foot Switch” function is active. A momentary contact closure will start the VitaPump; another momentary contact closure will stop (interrupt) vitamin metering.

### Remote Alarm Signal:

A second, 2-wire cable is provided for “Alarm” signals. When an “Alarm” condition is detected, the VitaPump will output a 5.0 VDC signal. The 5.0 VDC signal is a low-current control signal capable of controlling solid-state switches. However the 5.0 VDC alarm signal cannot be used to power a light or bell on its own. Connect it to the coil of a solid state relay or to an appropriate input on your PLC.

### Pump Status Signal:

A third, 2-wire cable is provided for a “Status” signal. Like the Alarm Signal above, it is 5.0 VDC low-current signal. This signal changes from low to high and back based on when the VitaPump motor is running.

## 5.0 Serial Mode: Remote Control by PC: Printer & PC Control

Serial Mode (See Setup: Serial Mode, Section 4.6) allows you to choose between two different methods of remote control and output for your VitaPump; Printer or PC Control.

Both methods allow you to control the VitaPump via RS-232 with a PC. You can upload flow rate, direction and batch weight limits. You can also start and stop the pump with single letter commands. The main difference between the two methods is in the output provided by the VitaPump to the PC.

In Printer Control, the output is identical to that of the printer, as shown in Section 4.4 of this manual.

In PC Control, you have an additional Print Command (P) available that returns a single line data string that has no labels. This type of data stream is easily captured and placed into a spreadsheet or similar report. Please see the example in Section 5.2 that follows. This method of control is commonly used in conjunction with a control program written by a third party.

You can use Win95 HyperTerminal (Windows 95/98) for uploading of VitaPump control parameters. Use the instructions (on the next pages) for accessing the HyperTerminal in your PC and for selecting the appropriate parameters.

*Once you have selected the HyperTerminal parameters, reduce the HyperTerminal window to one half of its original size. Open Note Pad ("Accessories" or "New Text Document" in HyperTerminal), reduce the Note Pad window to one half size. The Note Pad is used here as a text editor. Place the HyperTerminal window in the upper half of your monitor and the Note Pad window in the lower half of the monitor. Both windows are now displayed and are readily accessible.*

### 5.1 Printer: Commands & Data format

If you have selected **PRINTER** in Setup: Serial Mode, the VitaPump will recognize the following uploaded commands, and download metering data to and from your PC. The format of the **PRINTER** download is identical to the printer output detailed in section 4.4 Setup: Printer on the previous page.

**Uploading** a program from your PC to the VitaPump is straightforward: Create a program in the in Note Pad. Make sure the first line of the program is an upper case "**U**"; the last line of the program must be "**End**". If you wish to execute the program, send the single character "**R**" for "RUN". Each program statement must be followed by a carriage return ("Enter"). For example:

<i>U</i>	Initiates Uploading
<i>RATE 6.0</i>	Pump Rate of 6.0 g/min
<i>CW</i>	clockwise, <i>CCW</i> for counter clock-wise
<i>WGT 12.50</i>	Sets Batch Weight to 12.50 kg (x.xxx kg or xx.xx kg)
<i>END</i>	End of Program & "Enter"
<i>R</i>	"RUN", Executes Program

Use the following single character commands for Start / Stop

<i>R</i>	<i>for RUN</i>
<i>S</i>	<i>for STOP</i>

For example, if wish stop the vitamin metering, simply send "**S**" for STOP, if you wish to continue, send "**R**" for RUN.

Highlight all program steps including the final carriage return, select "Copy" in Note Pad **Edit** and then select "Paste to Host" in HyperTerminal **Edit**. You should see an "Uploading" message on the VitaPump display during transfer:

1. If the Upload occurs while in the "**Press RUN when Ready**" screen, the VitaPump will start the program once the upload is complete.
2. If the Upload occurs while a VitaPump program is running, the pump will stop, the balance is re-initialized and the tare is activated. After the balance is tared, the newly uploaded program starts at the beginning.

## 5.2 PC Control: Commands and Data format

If you have selected **PC CONTROL** in Setup: Serial Mode, the VitaPump will recognize uploaded commands from the PC. The format of the **PC CONTROL** download is different than that of **PRINTER**, and is detailed further below.

The **PC CONTROL** protocol consists of 4 main single character commands:

**U** Upload command sends settings from PC to the VitaPump. Each setting is contained on an individual line of text. Valid settings are:

<b>CW</b>	Sets pump direction to clockwise
<b>CCW</b>	Sets pump direction to counterclockwise
<b>RATE aa.a</b>	Sets mass flow rate to <b>aa.a</b> gm/min.
<b>WGT e.eee</b>	Sets Batch Limit to <b>e.eee</b> kg resets Batch Weight Limit
<b>CLEAR</b>	Resets Total Weight (TW) counter
<b>END</b>	Ends "upload" and returns to command mode

**R** Run command, starts VitaPump metering.

**S** Stop command, stops VitaPump, halts metering.

**P** Print command, gets a single line of data showing VitaPump status in this format:

**aa.aa bbb cccc.c dd.ddd e.eee ffff.fff X Y Z**

where...

aa.aa is current mass flow rate setting in gm/min.

bbb is actual pump speed (0-100%)

cccc.c is the current displayed balance weight in grams

dd.ddd is the current batch dispensed weight in kg

e.eee is the batch weight limit in kg

ffff.fff is the total weight dispensed in kg

X is 1 when the pump is running, 0 when stopped

Y is 1 when pump rate is maximum, 0 when normal

Z is 1 when batch is complete, 0 when dispensed weight < batch limit wgt.

Example command sequence: (All Caps)

Command	Action
<b>S</b>	Stop Pump
<b>U</b>	Upload the following settings
<b>CCW</b>	Pump direction = counterclockwise
<b>RATE 6.0</b>	Set pump rate to 6.0 gm/min.
<b>CLEAR</b>	Clear total weight
<b>END</b>	Ends upload session
<b>R</b>	Starts metering
<b>P</b>	Gets pump status.
	Response: 10.00 5 492.0 0.013 0.099 0.610 1 0 0

## 5.3 Win95/98 HyperTerminal Settings: *Uploading/Downloading of Programs/Data*

For Uploading of VitaPump programs from your PC, or Downloading of data for archival, you must use the “**Printer**” serial port located on the back panel of the VitaPump. Use an RS-232 cable (P/N: 080-073) to make the connection to your PC.

*The following Hyper Terminal setting procedure is intended for PCs with a **Window 95/98** software installation: Press the Windows 95/98 **START** key in the lower left corner of your screen, select “**Program**” then select and open “**Accessories**”, select “**Hyper Terminal**”, double-click at the HyperTerminal icon.*

1. From the “**Connection Description**” screen, select an icon and enter a file name, i.e. VitaPump. Press “**Ok**”
2. From the “**Phone Number**” screen, select “**Direct to Com 1**” in the box labeled “Connect Using\_.”, alternatively, select any other available Comport. Press “**Ok**”
3. From the “**Com 1 Property**” screen, select the following “Port Setting” parameters

3.1 Bits per Second: 9600  
3.2 Data Bits: 8  
3.3 Parity: None  
3.4 Stop Bits: 2  
3.5 Flow Control: None

Press “**Ok**”

**NOTE:** Make sure you enter same communications parameters in the VitaPump under **SETUP: Printer: Baud Rate=9600; Parity = None; Stop Bits = 2; Data Bits = 8; Set Print Delay = 0; set Print Time = 1.**

4. Go to “**File**” and open “**Properties**”, from the “**VitaPump Property**” screen, select the “**Setting**” screen, enter the following:

**Terminal Keys:** Select  
**Emulation:** Auto Detect  
**Backscroll Buffer:** 500

5. While still in the “**Setting**” screen, press “**ASCII Setup**” key & select the following from the “**ASCII Setup**” screen.

**Send Line Ends with Line Feed:** Select  
**Echo Typed Characters Locally:** Select  
**Line Delay** 0 msec.  
**Character Delay:** 0 msec

**Append Line Feeds.....:** No Selection  
**Force Incoming.....:** No Selection  
**Wrap Lines That Exceed .....** Select

Press “**Ok**” at the bottom of the “VitaPump Setup” screen.

Press “**Ok**” at the bottom of the “VitaPump Property Setting” screen

## 6.0 Manual Mode

Manual mode allows you to operate the VitaPump manually. You can select pump speeds from 0-100%, and set the direction, CW or CCW. In Manual mode, gravimetric metering (with a balance) is not possible. This is useful when priming the system is desired, or when the balance has failed and you need to run in manual mode. When metering in Manual mode, be certain to verify the speed required to obtain the correct addition rate.

From the Mode Select screen, scroll to Manual and press "Select". You will see the following screens:

<b>Mode Select: MANUAL</b>		
<b>Up</b>	<b>Down</b>	<b>Select</b>

<b>-MANUAL-</b>	<b>100.0%</b>
<b>Sw=0000</b>	<b>CW</b>

Use the RATE key to increase or decrease the motor speed.

Use the Double Arrow key to set or change the pump direction.

Use the RUN and STOP keys to start and stop the pump.

The SWITCH key provides access to 4 TTL outputs not available in other modes.

The TIME and \* keys do not function on the VitaPump.

The External RUN/STOP still functions normally in Manual mode.

## **Appendix “A”**

### Tandem Pump Head Installation and Maintenance

#### PLEASE NOTE:

SciLog Does Not Sell Individual Replacement Parts.

Replacement Parts Are Only Sold As Subassemblies.

We Regret Causing Any Inconvenience.

Contact SciLog With Any Questions At: 1-800-955-1993

**TANDEM™ Peristaltic Pump Head:**

The TANDEM peristaltic pump head is specifically designed for use with the **VitaPump** metering system. The TANDEM pump head (model 1081) will provide you with rugged reliability as long as common sense maintenance and good quality pump tubing are used.

The TANDEM pump head is driven by 160 RPM high-torque motor. The **VitaPump** motor is optically encoded and servo-controlled, thus the TANDEM pump head will maintain a constant output over a wide range of metering conditions.

**TANDEM Pump Head: Installation:**

1. Identify the front and back of the TANDEM. Two 8-32 mounting cap screws, as well as the pump shaft tang extend from the back of the TANDEM pump head.
2. Facing the front of the TANDEM, open the pump head by moving the black loading lever 180° to the left. The upper and lower pump shoe will move in opposite directions, thereby exposing the inside of the upper and lower pump shoe channels.
3. With the TANDEM pump head completely opened, locate the mounting holes for the two 8-32 cap screws inside the lower pump channel.
4. On the front panel of the VitaPump, locate the mounting holes and the slotted pump head coupler.
5. Before fastening the TANDEM, align the two mounting screws and pump shaft tang of the TANDEM with the holes and slotted coupler of the VitaPump front panel mounting plate.
6. Make sure the TANDEM pump shaft tang is properly seated in the mating slot of the pump head coupler, before fastening the TANDEM to the front panel of the VitaPump.

**TANDEM™ Peristaltic Pump Tubing / Rate Selection:**

For vitamin metering applications in the 1 to 30 gm/min. range, the TANDEM 1081 together with #14 Masterflex™ pump tubing is the most useful pump head/tubing combination. Other ranges can be accommodated with other tubing sizes.

The following chart shows tubing dimensions and the available flow rates based on tubing size, and the standard 160rpm motor:

	13	14	16	25	17	18
Tubing ID*: in	0.030	0.060	0.125	0.190	0.250	0.310
Tubing OD*: in	0.157	0.189	0.251	0.314	0.376	0.439
Tubing Wall*: in	0.063	0.063	0.063	0.063	0.063	0.063
Pump Rate Range*: gm/min	0.5 - 10	1.7 - 35.2	6.3 - 129	12.5 - 283	18.5 - 405	24.7 - 554
* Nominal Values						
<b>Pump Head Model:</b>	<b>TANDEM 1081</b>					

### **TANDEM™ Pump Tube Installation:**

1. Open the TANDEM pump head by moving the black loading lever 180° to the left. If you are going to use the upper pump channel, slip the tubing into the upper channel; that is over the pump roller cage. If the lower channel is used, feed the tubing through the lower channel, that is under the pump roller cage. *Do not loop a single piece of tubing through both the top and lower channel of the pump head.*



**WARNING: Do NOT mount or dismount the pump tubing while the VitaPump is running.**

2. Lock the tubing in place by pushing the loading lever 180° to the right. The tube retainer spring will automatically place the correct tension on the pump tubing to prevent tube “walking”.
3. With the TANDEM pump head closed, lightly pull the two ends of the tubing in opposite directions and away from the pump head. This pulling action insures that the pump tubing is taut and within the pump channel.

### **TANDEM™ Pump Tube Replacement:**

The pump tubing section located in the TANDEM pump head should be advanced at regular time intervals, if the VitaPump is heavily used. Only use high-quality, correctly sized pump tubing.



**WARNING: When advancing pump tubing, the used pump tube section must be moved to the pump discharge side, i.e. dispensing side. The used pump tube section is weakened and tends to collapse when placed on the suction side of TANDEM pump head.**

### **TANDEM™: Pump Tubing / Chemical Compatibility**

Selecting the right pump tube material is crucial to ensure high pump performance. Consider all aspects of your application when choosing your pump tube material: 1. chemical compatibility of the fluid and tubing, 2. operating temperature and pressure, as well as 3. cleaning / sterilization requirements.

# TANDEM™ Dual Channel Peristaltic Pump: *Parts Identification*

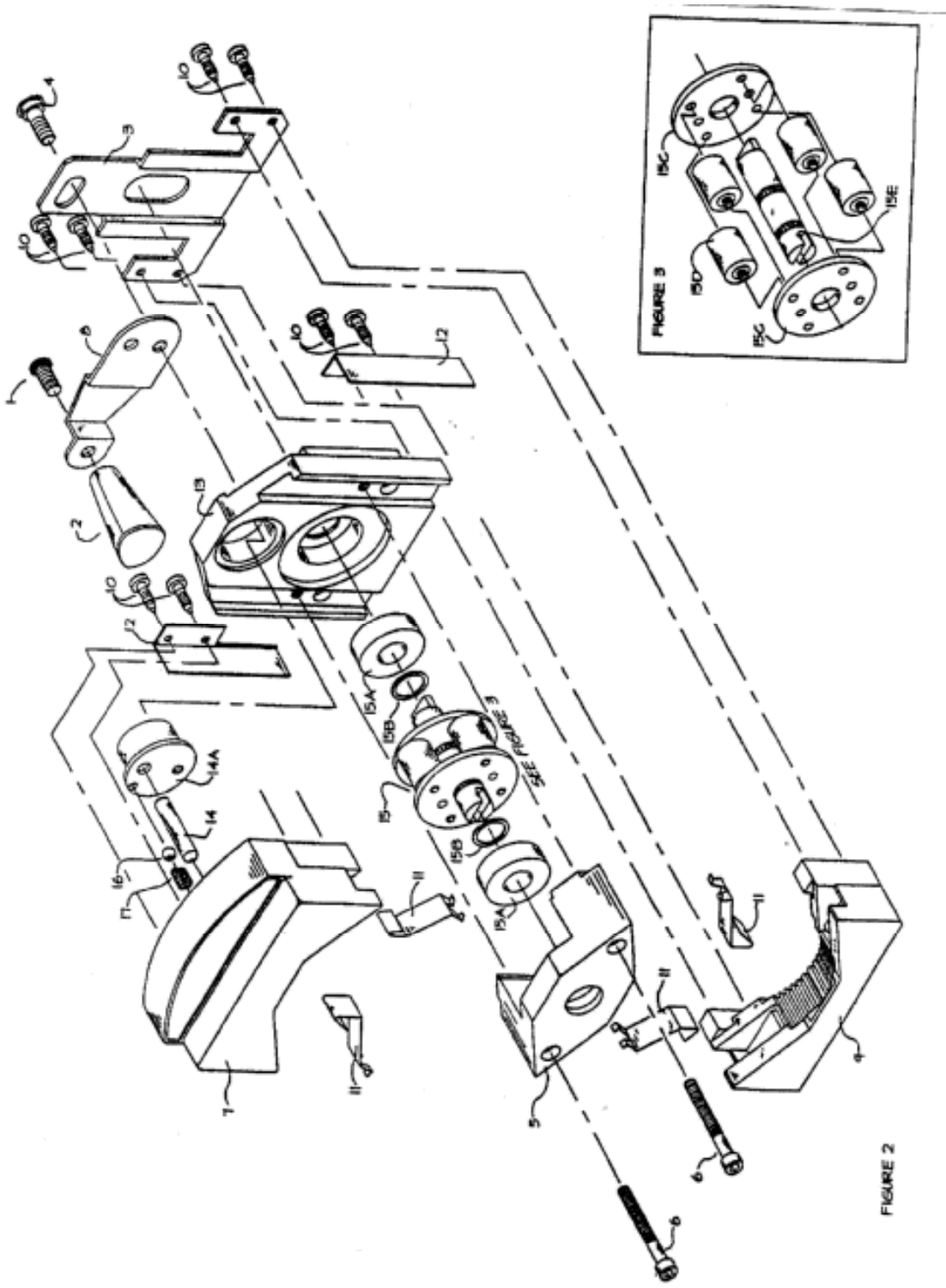

FIGURE 2

**PLEASE NOTE: REPLACEMENT PARTS ARE NOT SOLD INDIVIDUALLY**

**TANDEM™ Parts List:** Contact SciLog Inc (1-800-955-1993) to order replacement parts, mention model and serial number of pump head (either TANDEM 1081 or TANDEM 1082) on which the part will be used.

<b>Item</b>	<b>SciLog P/N</b>	<b>Description:</b>
1	500-330	Pump Lever Stud (1)
2	500-320	Pump Lever Knob (1)
3	500-240	Plate, Lower Cam (1)
4	500-210	Cam, Lower Pump Shoe (1)
5	500-410	Bearing Block, Front (1)
6	500-411	Bearing Block Cap Screw (2)
7	500-420	Pump Shoe, Upper (1)
8	500-310	Lever, Pump (1)
9	500-430	Pump Shoe, Lower (1)
10	500-452	Pump Shoe Screw (8)
11	500-440	Tube Holding Fork (4)
12	500-451	Pump Shoe Bracket (1)
13	500-450	Pump Base (1)
14	500-220	Cam, Upper Pump Shoe (1)
14A	500-230	Cam Shaft/Cylinder (1)
15 (Fig. 3)	500-100	Assembly, Roller Housing, 1081
	500-110	Assembly, Roller Housing, 1082
16	500-250	Cam Shaft, Ball (1)
17	500-260	Cam Shaft, Spring (1)
18	500-412	Pump Body Inserts (2)

**PLEASE NOTE: REPLACEMENT PARTS ARE NOT SOLD INDIVIDUALLY**



## **Appendix “B”**

FMI Q1 Pump Head  
Installation and  
Maintenance

### PLEASE NOTE:

Replacement Parts Are Not Sold Individually By  
Either FMI (The Manufacturer) Or SciLog.

All Replacement Parts Are Sold As Subassemblies.

We Regret Causing Any Inconvenience.

Contact SciLog With Any Questions At: 1-800-955-1993



# “Q” PUMP INSTRUCTIONS

## CERAMPUMP®

1506002

CONGRATULATIONS! The FMI “Q” PUMP LINE is one of the finest metering pump lines in the world. It features the unique valveless, variable, rotating and reciprocating pumping design of all FMI pump products and more. More consistent accuracy, more volume per stroke, more motor drive options and more diverse flow control options including a dial indicator, 4-20 milliamp stroke rate controller and dispenser.

## SAFETY INSTRUCTIONS

**!** Before using any Fluid Metering, Inc. product read the following safety instructions as well as specific product specifications and operating instructions.

**!** **Warning!** Fire, electrical shock or explosion may occur if used near combustibles, explosive atmosphere, corrosive air, wet environment or submerged in fluid.

- Turn off the electrical power before checking pump for any problems.
- Connect motor, speed controllers, or any other electrical devices based on Fluid Metering Inc. specifications. Any unauthorized work performed on the product by the purchaser or by third parties can impair product functionality and thereby relieves Fluid Metering, Inc. of all warranty claims or liability for any misuse that will cause damage to product and /or injury to the individual.
- Power cables and leads should not be bent, pulled or inserted by excessive force. Otherwise there is a threat of electrical shock or fire.
- Replace any in-line fuses only with fuse rating as specified by Fluid Metering, Inc.
- When pump/drive is under operation, never point discharge tubing into face or touch any rotating components of pump.
- In a power down thermal overload cut-in condition, unplug or turn off power to pump. Always allow a cool down period before restarting: otherwise, injury or damage may occur.
- For 30 seconds after power is removed from pump/drive: do not touch any output terminals. Electrical shock may occur because of residual voltage.

**!** **Caution!** Fire, electrical shock, injury and damage may occur if not used in accordance with Fluid Metering, Inc. specifications and operation instructions.

- Do not put wet fingers into power outlet of unit.
- Do not operate with wet hands
- Do not operate drive assemblies that require a hard mount (to be bolted down) unless they are mounted per Fluid Metering, Inc. specifications, if not injury may occur and/or damage to unit.
- Do not touch any rotating pump or motor components: injury may occur.
- Do not run pump dry, unless designed for that service.
- Running dry is harmful to the pump, and will cause excessive heating due to internal friction.
- Check pump rotation and inlet/outlet pump port orientation before connecting power to pump. If not injury may occur.
- When pulling out cords from outlets do not pull cord, grasp plug to prevent plug damage or electrical shock.
- Fluid Metering, Inc. Drive Motors become **HOT** and can cause a burn. **DO NOT TOUCH!**

## INSTALLATION & OPERATING TIPS

**1. CLEAN FLUIDS.** Abrasives in the pumped fluid may damage cylinder and piston surfaces and should, therefore, be avoided. Carbon cylinder liners and stainless steel pistons are particularly susceptible to abrasion by particulate matter in the pumped stream. Ceramic piston/cylinder components are more tolerant of suspended solids except solids that tend to flock and impede the movement of the piston in the cylinder.

**2. COMPATIBLE FLUIDS.** Pump only fluids compatible with materials of construction of the pump head you have selected.

**3. WET OPERATION.** The pumped fluid provides surface cooling and lubrication to the piston and cylinder of your FMI PUMP. Therefore, avoid dry operation (except pumps specifically designated “gas pump”).

**4. FLOW VOLUME AND DIRECTION.** Angular deflection of the cylinder with respect to the zero point on the calibration scale of your FMI “Q” PUMP controls flow magnitude and direction e.g., with the cylinder pointer at 10 on the left scale, fluid will be passed from the right port to the left port at 100% of the maximum rated volume; with the pointer at 10 on the right scale, fluid will pass from the left port to the right port at maximum rate. Set at 5 on the scale, flow rate will be 50% of maximum; at 4, it will be 40%; at 3, 30%, etc., etc. The flow control setting may be changed (including flow reversal) at any time while the pump is operating or

idle. Slightly loosen the two thumb screws and turn the STROKE LENGTH ADJUSTMENT KNOB. Retighten thumb screws once the desired setting is reached.

**5. PISTON SEALS.** The R408 seals that keep your PUMP piston dry are not “just ordinary plastic discs.” They are precisely cut and hot formed from sheets of a chemically inert fluorocarbon, specifically formulated for resistance to wear, abrasion, heat and chemical attack.

Each R408 seal possesses an exceptional mechanical memory which allows it to maintain a relatively constant wiping pressure on the piston, compensating for seal wear as it occurs. Properly maintained in clean condition, the original seals on a FMI PUMP may be expected to last the life of the pump. If they are removed for any reason, they should be carefully cleansed of all foreign particles prior to re-assembly. Seal seats must also be free of particles. (please see para 18)

**6. DIAL INDICATOR.** (optional) The Dial Indicator Kit is for fine adjustment and continuous monitoring of your “Q” pump flow rate settings.

To adjust Dial Indicator equipped pumps:

1. Loosen thumb screws, turn STROKE LENGTH ADJUSTMENT KNOB, moving cylinder assembly to neutral (zero-flow position).

2. Adjust indicator pointers until they read zero on both dials.

3. You are now ready for fine setting by turning STROKE LENGTH ADJUSTMENT KNOB until you achieve desired flow rate on dial. To prevent system backlash always turn STROKE LENGTH ADJUSTMENT KNOB two turns or one full revolution of large dial beyond desired setting, then adjust back.

**7. 4-20 mA CONTROL** for automatic response to remotely generated 4-20 milliamp signals is standard on V200 controllers. The input can be either grounded or ungrounded. The current source connects to terminal posts mounted on front cover assembly of the STROKE RATE CONTROLLER. Be sure to observe correct polarity. For complete hook-up and operating information see page 10.

**8. PRESSURE.** Do not operate pump against head pressures in excess of design specification. Drive arm on piston may bend or break under overload and other irreparable damage may be suffered. **Check your fluid circuit before applying power to the pump!**

**9. ELECTRICAL PROTECTION.** All FMI PUMPS are positive displacement instruments and should be protected by lowest possible “slo blow” fuse or circuit breaker electrical arrangements. “QV” units come equipped with .75 amp fuses.

**10. NOISE AT HIGH PUMP RATES.** A metallic hammering noise during operation of your pump (particularly high speed units such as QB, QD, QDX, and QV) when pumping liquids indicates

presence of gas bubbles in the pumping chamber which are reducing pumping capacity and may be damaging cylinder walls. Such bubbles may be traced to 1) a poor seal at the suction fitting, 2) fluid vaporization (cavitation) or, 3) degassing of the fluid.

a) To correct suction fitting leaks in stainless steel pump heads, remove fitting and wrap two layers of Teflon tape (standard Lab plumbing variety, 1 to 2 mil thick x 1/2" wide) tightly into the threads of the fitting. Replace fitting in cylinder port, drawing threads tightly on the Teflon tape. (see para 16).

b) To eliminate vaporization and degassing noise, reduce suction load. This may be accomplished by: 1) Using the 3/8" dia. TUBE ADAPTER R412-2 supplied with each pump on the suction line of the pump head to increase inside diameter of the suction line (use 1/2" dia. TUBE ADAPTER R412-6K on -3 PHM's.); 2) reduction of suction lift height; 3) pressurization of suction supply container; 4) locating pump below supply source to permit gravity flow aid; 5) reduce viscosity of fluid by heating or thinning; 6) reduce flow rate by adjusting pump to lower setting on flow scale; 7) install FMI PD-HF PULSE SUPPRESSORS in suction and discharge lines.

Improvements in noise abatement and pump life can be gained by putting pulse suppression hardware in the plumbing circuits adjacent to the pump suction and discharge ports - particularly with high speed pumps that are plumbed with rigid tubing. Theory holds that if part of a generated pulse is resiliently stored, the part not stored is smaller and thus easier to get into motion; the stored part of the pulse dissipating behind the part that is in motion sustains motion, causing an undulating flow to be transmitted rather than a series of pulses. Result: less noise, less energy used and less agitation of the pumped fluid. So for pulse noise and vibration problems, put a little resilience in your circuit. There are a number of rather easy ways to do it:

c) The simplest method is to use resilient tubing between the pump and the fluid circuit. Experiment a bit with standard elastomers - viton, hypalon, gum rubber, soft vinyl or other. Use only unreinforced tubing (reinforcement takes away the resilience). **Always shield this type of arrangement** so that a possible tube rupture will not endanger people or equipment.

d) Another popular pulse suppression arrangement involves a gas bubble trap as described in the final sentences of para. 12. A bubble in such a vertical trap will suppress pulse shock and noise temporarily. However, since gas and a liquid in contact under agitated conditions seldom stabilize, the trapped gas may absorb into the passing liquid and disappear leaving no pulse suppression or the fluid may contribute to the gas quantity, overload the trap and cause random pumping errors as occasional bubbles enter the flow stream. This can be overcome by fitting a soft slug of closed-cell-plastic foam or a soft pillow of thin-wall plastic tubing (ends sealed) into the vertical dead end extension of the fluid line. The gas trapped in the foam or pillow will provide the required resilience but will not be absorbed by the flow stream.

e) Since each fluid and circuit exhibits differing characteristics, a bit of experimentation may be necessary. The results are usually worth the effort.

**11. FOR BEST LOW FLOW PUMPING RESULTS:** Use a pump having a maximum flow rating as near

to the desired flow rate as possible and keep suction and discharge pressures essentially constant (see para 13). FMI pumps using R479 Low Flow Kits or designated LF are specifically designed for low flow/low dead volume, 1/4-28 flat bottom fittings.

**12. LOW FLOW BUBBLE PROBLEMS.** A common cause of trouble in metering pump applications requiring low flow rates - a few milliliters per minute or less - is the seemingly inevitable gas bubble trapped in the pumping head of the metering pump. It expands on the suction stroke and contracts on the discharge stroke, allowing little, if any, liquid to pass through the pump. Such bubbles, though often attributed to leaks in pump seals, can usually be traced to gases released by the pumped fluid in response to pumping agitation or pressure/temperature changes. When so identified, this potential source of metering pump error can be effectively controlled in most fluid circuits.

The familiar bubbles that form on the inside walls of a tumbler of tap water after it stands for a period of time at room temperature demonstrate the typical liquid degassing that results from pressure reduction (water line pressure to atmospheric) and/or temperature elevation (from ground ambient to air ambient). In this case, the bubbles contain air, hydrogen, carbon dioxide or other gaseous materials carried in the water; only small quantities of vaporized water are present. Some liquids respond to agitation and/or pressure/temperature changes by chemically separating into liquid and gas fractions; others simply vaporize, physically changing from liquid to gaseous form. Examples of liquids releasing gas or changing from liquid to gaseous form in response to agitation and temperature/pressure changes are numerous in the modern technical environment and many techniques have been devised to compensate for or correct their presence.

The most common practices for bubble control employ:

a) pressure on the suction side of the pump circuit to encourage gas retention in the liquid or,

b) employ natural buoyancy of the bubbles to carry them away from or through the pump head.

To apply pressure on the suction side of the pump, locate the pump physically below the supply vessel. Each two feet of elevation difference represents pressure of approximately one pound per square inch (psi). Bubbles that do occur will return to the supply vessel by buoyant lift. This is called a positive suction or flooded suction arrangement. If it is necessary to draw liquid up from the supply vessel to the pump head, negative suction pressure must be contemplated - again, approximately 1 psi per two feet of lift. Most liquids will release some gas when held at negative pressure and since the volume of gas released is generally proportionate to the volume of liquid subjected to the negative pressure, suction line diameter should be kept small for small flows (except heavy, viscous or tacky liquids which require large flow area for mobility). A vertical dead-end extension of the suction line can be provided above the pump suction port to trap line-generated bubbles before they enter the pump. This extension should be liquid filled at the start of a pumping period. Stand the pump vertically by loosening the screws and repositioning the Multi-Position Tilt Stand Q650 so that pump is in standing position, or hang the pump vertically by its base key slots. The discharge port should now be above the suction port allowing bubbles that enter the pump head to pass directly through with buoyant assist. Discharge lines should be inclined upward from pump head and bubble traps should be purged as often as necessary to

assure liquid flow continuity.

**13. SYSTEM ACCURACY FACTORS.** Several interrelated factors are involved in the exceptional operating accuracy possible in systems using FMI PUMPS. Of primary concern are the following:

a) FMI PUMP DISPLACEMENT precision is based on a simplified positive stroke mechanism which has no secondary linkages to produce stroke to stroke mechanical errors and has no gravity actuated or spring loaded valves to introduce random valve seating errors. The single mechanical linkage component between the PUMP piston and its drive elements is a precision spherical bearing which transforms circular drive motion into elliptical thrust motion (reciprocation). The total mechanical clearance of this linkage is less than 0.1% of the maximum pump stroke length or, approximately 0.0003". Thus it may be said that PUMP displacement precision (stroke to stroke) is in the order of the mechanical linkage clearance; that is to say, stroke to stroke displacement is reproducible to less than 0.5% within the rated capacity of a given pump model.

b) FMI PUMP VALVING is performed by a flat in the piston which is mechanically aligned with one cylinder port during the suction portion of each stroke and with the other cylinder port during the discharge portion of each stroke. The flat alignment is controlled by the single drive bearing discussed in the preceding sentences. The valve action is therefore mechanically precise, and free of random closure variations.

c) FLUID SLIP, a term commonly used to describe the migration of fluid around the internal moving parts of gear, lobe and vane pumps, is the volumetric difference between physical component displacement and fluid through-put of a pump system. In the FMI PUMP, slip loss refers to the fluid which passes through the clearance space (approx. .0002") between the piston and the cylinder wall. Since this clearance represents a restrictive passage of essentially constant dimension, it will be readily seen that the slip rate is determined by viscosity, pressure and time: e.g. assuming constant fluid viscosity and pressure, slip will be a smaller factor in a high repetition rate pump (short time per stroke) than in a low repetition rate pump. As viscosity increases and pressure decreases, time (or repetition rate) becomes less a significant contributor to slip loss.

d) STROKE REPETITION RATE is directly related to drive motor speed which in turn is influenced by work load and electrical supply voltage, i.e., motor speed decreases when work load increases and when electrical supply voltage (115 Volts AC) decreases. This motor speed variation may amount to as much as 15% for work load variations between zero discharge pressure and maximum rated discharge pressure. A 10% voltage drop may result in as much as 20% motor speed reduction when the pump is operating against a significant head pressure.

e) THE FLOW STABILITY (precision) of an FMI PUMP is therefore principally related to consistency in fluid slip rate and stroke repetition rate and these functions in turn are related to external system load factors such as viscosity, differential pressure and electric line voltage; i.e., when load factors remain essentially constant, slip rate and repetition rate remain essentially constant; when viscosity increases, fluid slip rate and stroke repetition rate both decrease; when differential pressure increases fluid slip rate increases and stroke repetition rate decreases.

In short, FMI PUMP PRECISION is influenced by



# IMPORTANT

## RECOMMENDED FMI PUMP MOUNTING FOR MAXIMUM PERFORMANCE

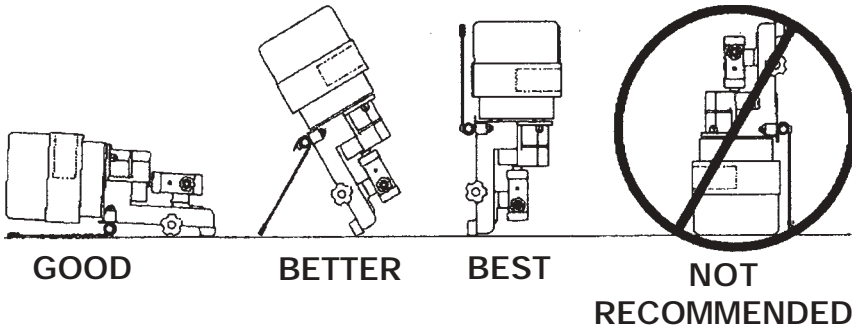

For maximum pump performance, mount the pump with motor at 12 o'clock and pump head at 6 o'clock position. This orientation will allow air bubbles that enter the pumping chamber to directly exit thru buoyant assist. Discharge lines should be inclined upward from pump head.

fluctuations of fluid differential pressures, fluid viscosity and electric line voltage. When these factors are controlled predictably reproducible pumping precision better than 0.5% may be expected.

## MAINTENANCE & REPAIR INSTRUCTIONS

**14. LUBRICATION.** Pump drive elements are provided with oil fittings at all appropriate points. Use high grade machine oil at regular intervals. A dab of good grease on PISTON DRIVE PIN just before it is inserted into the RADIAL BEARING in the SPINDLE ASSEMBLY does a world of good for the bearing and pin.

**15. CHANGING THE LIQUID END OF YOUR FMI "Q" PUMP.** (figures 1,2).

- a) To remove "Q" Pump Head Module (QPHM):
1. Turn power off.
  2. Rotate STROKE LENGTH ADJUSTMENT KNOB to position PUMP HEAD CARRIER Q410-2 all the way to the extreme right or left of scale (fig. 1).
  3. Rotate SPINDLE ASSEMBLY Q424 to place PISTON DRIVE PIN at 3 or 9 o'clock position (facing cylinder head).
  4. Loosen two KNURLED NUTS.
  5. Lift QPHM and draw gently away from Q424 SPINDLE ASSEMBLY (fig. 2).
  6. Move QPHM up and to the left while slipping DRIVE PIN out of RADIAL BEARING.

- b) To replace QPHM:
1. With PISTON ASSEMBLY R423 extending approximately 1-1/4" from CYLINDER NUT R406K and DRIVE PIN in the 3 or 9 o'clock position, insert PIN into the RADIAL BEARING in the SPINDLE ASSEMBLY.
  2. Slide QPHM into position on BASE making sure locator on bottom of CARRIER Q410-2 drops into slotted portion of FOLLOWER Q454-2 on base.
  3. Tighten KNURLED NUTS on Q616 assembly.

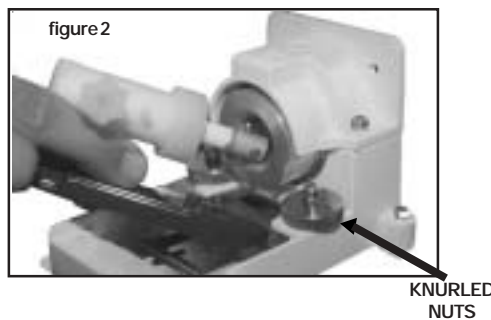
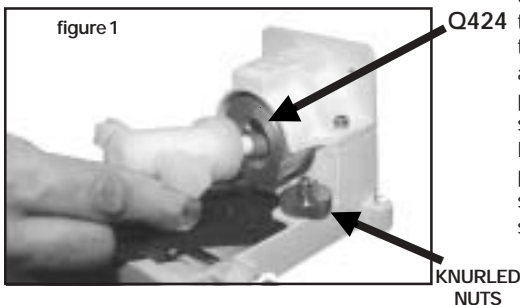

## 16. CHANGING FITTINGS ON STAINLESS STEEL PUMP HEADS IMPORTANT!

Fittings screwed too tightly into stainless steel pump heads will contact port seals and may cause piston/cylinder damage. Use extra layers of Teflon tape on threads when necessary to avoid such excessive penetration.

**17. CLEANING PUMP HEAD.** Routine flushing with solvent before shut-down will suffice for most applications - set pump for maximum stroke and operate until solvent appears clear at discharge port. If periodic teardown for detail cleaning is required, remove parts with care to avoid damage to piston, cylinder and gland. Wipe all parts with lintless oil saturated cloth. Operate by hand after reassembly to assure free movement of parts prior to application of power.

**17.1 CAUTION!** Ceramic piston/cylinder sets are particularly sensitive to neglect and may "freeze" if allowed to dry out without adequate cleansing. Some users actually remove the piston from the cylinder after solvent cleaning and store the component parts in disassembled condition until the pump is again required. Others fill a loop of flexible tubing with fluid that will thin or neutralize the last fluid pumped. They then connect one end of the tube to the pump suction port, the other to the discharge port. With this loop positioned above the pump head, the ceramic surfaces and seal areas will stay moist and mobile for extended idle periods. If, however, a piston (ceramic or stainless steel) does freeze in the cylinder, **DO NOT TRY TO FORCE IT FREE!** Be gentle. Try to remove the pump head (refer para 15) from the base assembly so that the whole assembly can be soaked in a suitable solvent. If the head is not conveniently

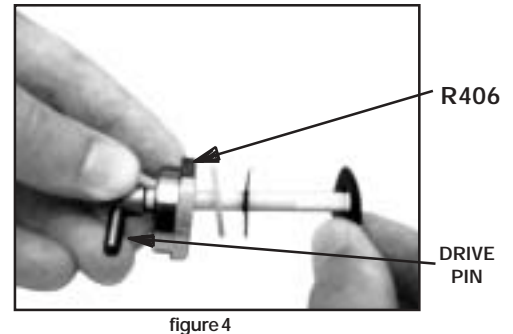
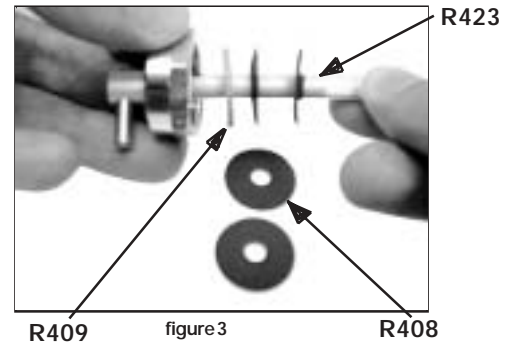

removable, the tube loop discussed in the prior paragraph may permit solvent to dissolve the "frozen" residue in reasonable time. If all else fails, pack it all up and ship it back to the factory with a note telling us what you think might be left inside - sometimes we're lucky. Having a spare pump head on hand in case of emergency is always a good idea.

**17.2 SANITARY SERVICE.** FMI sanitary pump heads, designated SAN are designed to conform with the cleansing standards of the U.S. Food and Drug Administration.

- To clean individual component parts:
- a) Unscrew 2 CYLINDER NUTS R406-S and 2 PORT NUTS 110348-P.
  - b) Remove piston and seal components released by step a) above;
  - c) Use fingers to wiggle LINER R407-C slipping it from CYLINDER CASE R405-SAN;
  - d) Cleanse and sterilize component parts as per government regulations for parts manufactured of Alumina Ceramic, Type 316 Stainless Steel and Teflon. After cleaning, reassemble the components as follows:
  - e) Assemble piston/seal components as per instructions para 18 a,b,c;
  - f) Orient CYLINDER LINER R407-C in CYLINDER CASE R405-SAN in such a manner that the side port flats on CYLINDER LINER R407-C should be visible through the side port openings on CYLINDER CASE R405-SAN.
  - g) Place one each port seal component R412-T into each side port of CYLINDER CASE R405-SAN using finger pressure across the two ports to assure flush seating of the seal surfaces on the cylinder liner flats.
  - h) Apply PORT NUT 110348-P to each port, finger tight.
  - i) Carefully insert piston into cylinder liner until threads of CYLINDER NUT R406-S meet threads of CYLINDER CASE R405-SAN. Tighten NUT R406-S finger tight.

Continued on Page 12

j) Place head seal components R413 and R489 into the head end of CYLINDER CASE R405-SAN, apply CYLINDER NUT R406-S.

k) Wrench tighten each PORT NUT 110348-P 1/6 turn.

l) Wrench tighten each CYLINDER NUT R406-S 1/2 turn, piston end first.

**18. PISTON SEAL REPLACEMENT** (please see para 5.) When R408 SEALS are replaced, the following procedure should be followed: (please see figs. 3,4)

a) Place GLAND NUT R406 and GLAND WASHER R409 on PISTON ASSEMBLY R423.

b) First "form" lip of LIP SEAL around piston by gently placing a LIP SEAL R408 on piston, **lip side last**. Carefully rotate the seal on the piston

to avoid damage to the lip while passing over the flat to the piston neck. **Then remove seal and reverse lip direction** (fig. 3).

c) Gently place one "formed" LIP SEAL R408 on piston, **lip side first**, carefully rotating the seal on the piston until it is past the flat and on the piston neck.

d) Gently place one LIP SEAL R408 on piston, **lip side last**. Carefully rotate the seal on the piston to avoid damage to the lip while passing over the flat to the piston neck (fig. 4).

e) Insert piston into cylinder approximately one inch.

f) Apply GLAND NUT R406 to cylinder threads and tighten.

**19. PISTON SEAL SETTING.** After installing new

lip seals (part R408) in pump head it is recommended that the seals be set (formed in place) by fluid pressures generated by pump action. To accomplish this:

a) Operate the pump spindle clockwise for 10 or 20 strokes at maximum setting, handling water (left to right mode facing pump head) with suction line blocked or pinched off. This will create a vacuum in the pump head, permitting atmospheric pressure to shape the outer seal member tightly around the piston.

b) Reverse the pumping direction (pump head angle reversal) and intermittently block the line leading from the left hand port. This will generate pressure in the seal area of the pump head, causing the inner seals to form intimately around the piston.

## Q PUMP HEAD MODULE - PARTS PRICE LIST

PART NO.	DESCRIPTION	PART NO.	DESCRIPTION
Q410-2	CARRIER	R412-1	ADAPTER, S.S. 1/4 NPT TO 1/4" I.D. TUBE
Q410-3	CARRIER STAINLESS STEEL	R412-2	ADAPTER, S.S. 1/4 NPT TO 3/8" I.D. TUBE
Q665	SPACER	R412-0K	ADAPTER, FLUOROCARBON 1/8" I.D. TUBE
R405-K	CYL CASE, FLUOROCARBON, DBL CAP	R412-1K	ADAPTER, FLUOROCARBON 1/4" I.D. TUBE
R405-1K	CYL CASE, FLUOROCARBON, STANDARD	R412-2K	ADAPTER, FLUOROCARBON 3/8" I.D. TUBE
R405-S	CYL CASE, STAINLESS STEEL	R412-5K	ADAPTER, FLUOROCARBON 1/4-28 THD
R405-1S	CYL CASE, SS, TEMP GLAND	R412-6K	ADAPTER, FLUOROCARBON 1/2" I.D. TUBE
R405-SAN	CYL CASE, SANITARY STAINLESS STEEL	R412-07	ADAPTER, S.S. 1/4" I.D. TUBE, SAN
R405-SG	CYL CASE, SS ISOLATION GLAND	R412-08	ADAPTER, S.S. 3/8" I.D. TUBE, SAN
R406-K	GLAND NUT, FLUOROCARBON	R412-1T	ADAPTER, TEFLON 1/4" I.D. TUBE, SAN
R406-0K	GLAND NUT, FLUOROCARBON 1/8" PISTON	R412-2T	ADAPTER, TEFLON 3/8" I.D. TUBE, SAN
R406-1K	GLAND NUT, FLUOROCARBON 1/4" PISTON	R413	CYLINDER HEAD SEAL
R406-2K	GLAND NUT, FLUOROCARBON 3/8" PISTON	R413-1	CYLINDER HEAD SEAL, R405-1K
R406-3K	GLAND NUT FLUOROCARBON	R419	CYLINDER PORT SEAL, R405-S
R406-S	CYLINDER NUT R405-S, R405-SAN	R423-1C*	PISTON
R407-0	CYLINDER LINER	R423-2C*	PISTON
R407-1	CYLINDER LINER	R423-3C*	PISTON
R407-2	CYLINDER LINER	R423-0S	PISTON
R407-1C*	CYLINDER LINER	R423-1S	PISTON
R407-2C*	CYLINDER LINER	R423-2S	PISTON
R407-3C*	CYLINDER LINER	R479	LOW FLOW KIT (FITS R405-S)
R408-1A	LIP SEAL, RULON AR 1/4"	R489	SPACER, SANITARY CYLINDER GROUP
R408-2A	LIP SEAL, RULON AR 3/8"	R490-1	PORT SLEEVE, SANITARY CYLINDER GROUP
R408-0J	LIP SEAL, RULON J 1/8"	R520-1T	ADAPTER, TEFLON 1/4" O.D. STRAIGHT, SAN
R408-1J	LIP SEAL, RULON J 1/4"	R520-2T	ADAPTER, TEFLON 3/8" O.D. STRAIGHT, SAN
R408-2J	LIP SEAL, RULON J 3/8"	H476-K	SML TUBE ADAPTER SET, 1/8" O.D. (OPTL)
R408-1T	LIP SEAL, TEFLON 1/4"	110017-10	SCREW, SKT HD CAP 1/4-20 X 5/8"
R408-2T	LIP SEAL, TEFLON 3/8"	110311	NUT, SQUARE 1/4-20
R408-3A	LIP SEAL, RULON AR 1/2"	110348-P	SAN PORT NUT, PLASTIC
R408-3T	LIP SEAL, TEFLON 1/2"	110348-S	SAN PORT NUT, STAINLESS STEEL
R409-0	GLAND WASHER, TEFLON 1/8"	110384-K	FERRULE NUT 1/4, KYNAR
R409-1	GLAND WASHER, TEFLON 1/4"	110384-T	FERRULE NUT 1/4", TFE
R409-2	GLAND WASHER, TEFLON 3/8"	110847-01	BARBED FITTING 10-32 UNC-2B 1/8" ID TUBING
R409-3	GLAND WASHER TEFLON 1/2"	200182-01	CYL CASE, SS HIGH TEMP GLAND

**Call SciLog  
for Info!**

\* CERAMIC PISTONS & CYLINDER LINERS SOLD AS SETS ONLY

PLEASE NOTE: REPLACEMENT PARTS ARE NOT SOLD INDIVIDUALLY

# SANITARY PUMP HEAD MODULE

