

FilterTec Plus Operations Manual



FilterTec Plus Applications:

Dead End Filtration* (DEF)
Filterability Studies
Filter Scale-up Studies
Filter Device Evaluation

*Also called Direct Flow Filtration (DFF)

SciLog Manual, Software & Applications Copyrighted
Rev E2A, 09/09, Firmware Version 0.11X, P/N 300-031

(This Page Intentionally Left Blank)



WARRANTY POLICY, PRODUCT RETURNS, ACCEPTABLE USE, AND OTHER RESTRICTIONS

1. WARRANTY AND RETURNS POLICY:

SCIOLOG, INC. EXPRESSLY WARRANTS THE EQUIPMENT MANUFACTURED BY IT ONLY AS SET FORTH HEREIN. SCIOLOG, INC. MAKES NO OTHER WARRANTIES, EITHER EXPRESS OR IMPLIED (INCLUDING WITHOUT LIMITATION WARRANTIES AS TO MERCHANTABILITY OR FITNESS FOR A PARTICULAR PURPOSE). IN ADDITION, THE FOLLOWING SHALL CONSTITUTE THE SOLE AND EXCLUSIVE REMEDIES OF BUYER FOR ANY BREACH BY SCIOLOG, INC. OF ITS WARRANTY HEREUNDER.

A. PRODUCT WARRANTY – SciLog, Inc. warrants products it manufactures against defects in materials and workmanship for one (1) year from the date of shipment from SciLog, Inc. in normal use and service. If any products fail to conform to this warranty within the first ninety (90) days of the warranty period, SciLog, Inc. will, at its option, repair or replace such goods returned. If any products fail to conform to this warranty for the remainder of the warranty period, SciLog, Inc. shall furnish necessary replacement parts free of charge.

B. PARTS WARRANTY - SciLog, Inc. warrants service parts against defects in materials and workmanship for ninety (90) days from the date of shipment from SciLog, Inc. in normal use and service. If any service parts fail to conform to this warranty, SciLog, Inc. shall furnish necessary replacement parts free of charge.

C. WARRANTY LIMITATIONS - These warranties are subject to the following conditions:

1. Upon discovery of such non-conformity, SciLog, Inc. will be given prompt written notice with a detailed explanation of the alleged deficiencies.

2. The product or part must be properly installed, operated and maintained in accordance with SciLog, Inc. specifications.

3. The product or part must not be operated above rated load capacity or subject to accident, alteration, misuse, or abuse.

4. The product must not have been repaired or serviced by anyone other than SciLog, Inc. or one of its authorized dealers.

5. SciLog, Inc. shall have a reasonable time to repair or replace the effective product.

6. The buyer is responsible for shipping the product to SciLog, Inc. SciLog, Inc. is responsible for shipping the product back to the buyer.

D. RETURN POLICY - Any item may be returned within thirty (30) days from the date of shipment from SciLog, Inc. If the box is unopened (the original factory seal is intact), SciLog, Inc. will refund the full credit to the buyer. If the box is opened (the original factory seal is not intact), SciLog, Inc. will refund the full credit less a \$75 inspection fee and repair labor/parts/materials cost (if applicable) to the buyer. No returns will be accepted after thirty (30) days from the date of shipment from SciLog, Inc. The buyer is responsible for shipping the product to SciLog, Inc.

2. INTELLECTUAL PROPERTY

The sale and delivery of the SciLog, Inc.'s equipment and/or software to Buyer shall in no way transfer to Buyer any right of ownership in any patents, copyrights, trademarks, technologies, designs, specifications, drawings, or other intellectual property incorporated into the equipment and/or software.

3. DISCLAIMER OF DAMAGES

IN NO EVENT SHALL SCIOLOG, INC. BE LIABLE FOR ANY TYPE OF SPECIAL CONSEQUENTIAL, INDIRECT, INCIDENTAL OR PENAL DAMAGES, WHETHER SUCH DAMAGES ARISE OUT OF OR ARE A RESULT OF BREACH OF CONTRACT, WARRANTY, TORT (INCLUDING NEGLIGENCE), STRICT LIABILITY OR OTHERWISE. Such damages shall include but not be limited to loss of profits or revenues, loss of use of the equipment or associated equipment, cost of substitute equipment, facilities, down time costs, increased construction costs or claims of Buyer's customers or contractors for such damages. Buyer agrees that in the event of a transfer, assignment, or lease of the equipment sold hereunder Buyer shall secure for the SciLog, Inc. the protection afforded to it in this paragraph.

4. LIMITATION OF LIABILITY

The SciLog, Inc. shall not be liable for any loss, claim, expense or damage caused by, contributed to or arising out of the acts or omissions of Buyer or third parties, whether negligent or otherwise. In no event shall the SciLog, Inc.'s liability for any cause of action whatsoever exceed the cost of the item giving rise to the claim, whether based in contract, warranty, indemnity, or tort (including negligence). Any suit arising hereunder must be commenced within one (1) year from the date in which the cause of action accrues. Except as provided in Article 3, the SciLog, Inc. shall not indemnify any party.

5. NO RESPONSIBILITY FOR GRATUITOUS INFORMATION OR ASSISTANCE

If SciLog, Inc. provides Buyer with assistance or advice which concerns any parts, products, service supplied hereunder or any system or equipment in which any such part, product or service may be installed and which is not required pursuant hereto, the furnishing of such assistance or advice shall not subject SciLog, Inc. to any liability, whether based in contract warranty, tort (including negligence) or otherwise.

6. INTERNATIONAL SALES EXPORT

Buyer EXPRESSLY agrees and verifies that the purchased product(s) will not be transferred or exported to third parties or foreign nationals and that Buyer is the final end-user of the product. Export or transfer of any SciLog product without the EXPRESS written authorization of the SciLog, Inc. is strictly prohibited and may violate US trade laws and regulations, thereby subjecting the Buyer to civil and criminal liability.

7. REVISIONS TO THIS POLICY

From time to time the Company may revise the terms of this Agreement. Company will make its best efforts to inform customers of these revisions. The most current revision of these terms may be accessed over the internet by accessing the webpage located at: <http://www.scilog.com/warranty>

REGISTER YOUR PRODUCT(S) WITH SCIOLOG, INC. IMMEDIATELY AT:

<http://www.scilog.com/register>



Phone: 608-824-0500 Fax: 608-824-0509

8845 South Greenview Drive, Suite 4

Middleton, Wisconsin 53562 USA

Precautions:

READ this manual **BEFORE** operating or servicing this equipment.



FOLLOW these instructions carefully.

SAVE this manual for future reference.



DO NOT allow untrained personnel to operate, clean, inspect, service or tamper with this equipment.

ALWAYS DISCONNECT this equipment from the power source before cleaning or performing maintenance.

CALL SCILOG for parts, information and service.

	 WARNING
	DISCONNECT ALL POWER TO THIS UNIT BEFORE INSTALLING, SERVICING, CLEANING, OR REMOVING THE FUSE. FAILURE TO DO SO COULD RESULT IN BODILY HARM AND/OR PROPERTY DAMAGE.

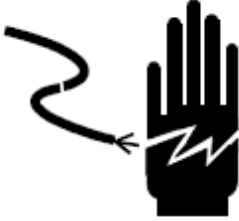
	 CAUTION
	OBSERVE PRECAUTIONS FOR HANDLING ELECTROSTATIC SENSITIVE DEVICES.

	 WARNING
	ONLY PERMIT QUALIFIED PERSONNEL TO SERVICE THIS EQUIPMENT. EXERCISE CARE WHEN MAKING CHECKS, TESTS AND ADJUSTMENTS THAT MUST BE MADE WITH POWER ON. FAILING TO OBSERVE THESE PRECAUTIONS CAN RESULT IN BODILY HARM.

	 WARNING
	FOR CONTINUED PROTECTION AGAINST SHOCK HAZARD, CONNECT TO PROPERLY GROUNDED OUTLET ONLY. DO NOT REMOVE THE GROUND PRONG.

PRÉCAUTIONS:

LISEZ ce manuel AVANT de faire fonctionner ou d'entretenir cet équipement.

SUIVEZ attentivement ces instructions.

CONSERVEZ ce manuel pour future référence.

NE LAISSEZ PAS du personnel non qualifié utiliser, nettoyer, inspecter, entretenir, réparer ou manipuler cet équipement.

DÉBRANCHEZ TOUJOURS cet équipement de la source de courant avant de nettoyer ou d'exécuter l'entretien.

APPELEZ SCILOG pour pièces détachées, renseignements et entretien.

	 ATTENTION
	DÉBRANCHEZ TOUT COURANT DE CETTE UNITÉ AVANT DE FAIRE L'INSTALLATION, D'EFFECTUER L'ENTRETIEN, LE NETTOYAGE OU AVANT DE RETIRER LE FUSIBLE. NE PAS OBSERVER CES PRÉCAUTIONS RISQUERAIT DE CAUSER DES BLESSURES CORPORELLES OU/ET D'ENDOMMAGER L'ÉQUIPEMENT.

	 PRUDENCE
	SOYEZ PRUDENT LORSQUE VOUS MANIPULEZ DES APPAREILS SENSIBLES À L'ÉLECTROSTATIQUE.

	 ATTENTION
	AUTORISEZ SEULEMENT LE PERSONNEL QUALIFIÉ À ENTREtenir CET ÉQUIPEMENT. SOYEZ PRUDENT LORSQUE DES VÉRIFICATIONS, TESTS ET AJUSTEMENTS DOIVENT ÊTRE EFFECTUÉS SOUS TENSION. NE PAS OBSERVER CES PRÉCAUTIONS RISQUERAIT DE CAUSER DES BLESSURES CORPORELLES.



	 ATTENTION
	POUR ASSURER UNE PROTECTION CONTINUE CONTRE UNE DÉCHARGE ÉLECTRIQUE, BRANCHEZ UNIQUEMENT SUR UNE PRISE CORRECTEMENT RELIÉE À LA TERRE. NE RETIREZ PAS LA FICHE DE TERRE.

Table of Contents

PRECAUTIONS.....	4
STANDARDS:.....	7
INSTALLATION & START-UP:.....	7
MAINTENANCE & CLEANING:.....	7
INTRODUCTION:.....	7
FILTERTEC PLUS MAINTENANCE.....	9
FILTERTEC PLUS SYSTEM SPECIFICATIONS:.....	11
INSTALLATION OF THE USB DRIVER:.....	13
PART A: FILTERTEC PLUS HARDWARE.....	14
1.0 OVERVIEW:.....	16
2.0 FRONT PANEL: DATA ENTRY & DISPLAY.....	17
3.0 BACK PANEL: INTERFACE OPTIONS.....	18
4.0 PRESSURE SENSOR INSTALLATION:.....	21
PART B: FILTERTEC PLUS™ SOFTWARE.....	22
1.0 SOFTWARE OVERVIEW: MAIN MENU.....	23
2.0 CONSTANT RATE MODE: CONSTANT RATE/ PRESSURE FILTRATION.....	26
2.1 Pump Re-calibration:.....	27
2.2 CONSTANT RATE Mode: Alarm Limits.....	29
3.0 CONSTANT PRESSURE: CONSTANT PRESSURE FILTRATION.....	32
3.1 CONSTANT PRESSURE: Alarm Limits.....	34
4.0 PROGRAMMABLE R-P: HOW TO GENERATE A PROGRAMMABLE R-P PROGRAM.....	37
4.1 PROGRAMMABLE R-P: Setup.....	40
4.2 PROGRAMMABLE R-P: Alarm Limits.....	42
5.0 SETUP.....	44
5.1 Setup: Scale.....	45
5.1.1 Ohaus Adventurer Pro Balance Parameters:.....	46
5.2 Setup: Clock.....	47
5.3 Setup: Test Mode:.....	48
5.4 Setup: Ethernet.....	49
5.5 Setup: Printer.....	50
5.6 Setup: Analog.....	51
5.7 Setup: Pressure Sensor.....	52
5.7.1 Setup: Pressure Sensor, Calibration.....	53
5.8 Setup: Pump.....	54
6.0 MANUAL:.....	56
7.0 DATA ACQUISITION:.....	56
7.1 FilterTec Plus SciDoc Data Collection Software:.....	57
7.2 PC HyperTerminal Settings:.....	61
APPENDIX “A” APPLICATION EXAMPLES.....	62
FilterTec Plus Settings and Parameters Worksheets.....	65
APPENDIX B: TROUBLESHOOTING.....	66
A. Peristaltic Pump Heads.....	67
B. Piston and Magnetic Gear Heads.....	69
C. SciDoc Documentation Software.....	70
D. FilterTec Plus Specific issues.....	71

Standards:

The FilterTec Plus™ conforms to the following standards:



EN 61326-1:2006, Class B
EN 6100-3-2:2006
EN 6100-3-3:1995 +A1:2001 +A2:2006
EN 61010-1 Issued: 2001/03/01
UL 61010-1 Issued: 2004/07/12 Ed.2



And is certified to: CAN/CSA-C22.2 No 61010-1 Ed.2

Installation & Start-Up:



Installation of the FilterTec Plus™ System must be carried out only by trained personnel in accordance with the relevant regulations and this operations manual.

Make sure that the technical specifications and input ratings of the FilterTec Plus™ are observed. See "FilterTec Plus™ Specifications".

The protection provided by this equipment may be impaired if the FilterTec Plus™ is used in a manner inconsistent with this manual or for purposes not specified by the manufacturer.

Maintenance & Cleaning:

The FilterTec Plus™ is practically maintenance free. The SciPres™ disposable sensors used with the system come pre-calibrated from the factory and require no maintenance. The Tandem™ peristaltic pump head should periodically have tubing debris cleaned from it, but requires no lubrication.

To remove dust, dirt and stains, the outer surfaces of the FilterTec Plus™ may be wiped using a soft, non-fluffing cloth moistened with water. If required, you may also use a mild detergent or 2-propanol.

The SciPres™ disposable sensors may be sanitized with 0.1 Molar NaOH, or 2-propanol. They may be autoclaved up to twice, and newer units with grey rings around the cable connector may be gamma irradiated.

Introduction:

You will find the FilterTec Plus™ System easy to use, and expands on the capabilities of the FilterTec by communicating with up to three scales at once. The state-of-the-art hardware and software design of the FilterTec Plus™ allows you to control measure and document your filtration processes. With proper maintenance, the FilterTec Plus™ System will provide many years of excellent service and performance.



Please read the following instructions carefully!

Inspections: Unpack the FilterTec Plus and accessories carefully from the carton. Cross-check the contents against your purchase order to verify that all parts are included and undamaged.

Please do the inspection now, even if the FilterTec Plus is not used immediately. Many carriers must receive damage claims within seven days of delivery. Please retain all packing material so unit may be shipped safely, if necessary.

SciLog Customer Service:

If you need assistance, please call: **1-800-955-1993** or **1-608 -824-0500**

SciLog Customer Service personnel will be able to serve you more efficiently if you have the following information:

- Serial number (back panel) and model name of the equipment.
- Installation procedure you used.
- Concise list of symptoms.
- List of operating procedures and conditions you were using when problem arose.

Warranty Repair: Units covered under warranty will be repaired and returned to you at no charge. If you have any questions about applicability, please contact SciLog.

Non-warranty Repair: For out-of-warranty repair, contact the SciLog Customer Service Department. A SciLog representative will discuss service options with you and can assist in making arrangements to return the equipment, if necessary.

Repair Procedure: Before returning any SciLog equipment for repair or service, contact SciLog to obtain an RGA Number. To return a piece of equipment:

Carefully pack the unit to prevent damage in transit. Check with SciLog regarding the proper method of shipment. No responsibility is assumed by SciLog for damage caused by improperly packaged instruments. Indicate the RGA Number on the carton and on the packing slip. Always insure for the replacement value of the unit.

Include a description of the symptoms, your name, return address, phone number, RGA number and purchase order to cover repair costs, return and shipping charges, if your institution requires it. Ship to:

SciLog Inc.
8845 S. Greenview Drive.; Suite 4
Middleton, WI 53562-2562

FilterTec Plus Maintenance

Preventative maintenance should be performed on the FilterTec Plus at least once a year.

Fill Out this Form & Fax it to SciLog at FAX: 608-824-0509.

SciLog will send you a **loaner pump for one week** if you request it. **\$350/week**

This price includes the cost of next day shipping & insurance to send the loaner to you.

Use the packing material from the loaner & send your pump to:

SciLog Inc.
8845 S. Greenview Dr.
Middleton, WI, 53562

SciLog will disassemble, clean and lubricate the pump head, **\$350**
change the seals if appropriate, inspect the motor, test, recalibrate, and generate a Performance Validation for your FilterTec Plus. If your pump needs a new motor or pump head, then we will contact you & get your approval before replacing them. A new motor is \$350; a new piston head is \$645; a new peristaltic Tandem head is \$235. Most of the time, cleaning and recalibration is all that is needed to insure many years of service. Price includes the cost of SciLog shipping your pump back.

Once you receive your cleaned/repared FilterTec Plus, use the packing material to repack the loaner and send it back to SciLog.

Assuming no replacement parts are required,

Total Cost, including Loaner and Shipping: **\$700**

Please Check all of the following that are appropriate:

Yes, I need my FilterTec Plus cleaned and recalibrated.

Yes, I need a loaner FilterTec Plus sent to me.

PO# _____ or Credit Card# _____

Expiration Date _____

Send the Loaner and/or Repaired / Cleaned FilterTec Plus to:

Company: _____

Address: _____

Contact: _____

Contact Phone #: _____

Contact Fax #: _____

Contact Email: _____

Call SciLog Customer Service at 800-955-1993 with any questions.

(This Page Left Intentionally Blank.)

FilterTec Plus System Specifications:

Mechanical:

- **Dimensions:** Width: 5.75 in (14.6cm); Height: 8.5 in (212.6); Depth: 11in (27.9)
- **Weight:** 14 lbs (6.4kg)
- **Enclosure:** Aluminum / Steel; Corrosion Resistant, Recessible Handle
- **Pump Head / Motor Options:**
- **Three Masterflex Easy-Load II (77201-60) adjustable occlusion pump heads with 8 RPM motor**, accommodates thin-walled (0.060") pump tubing: #13, 14, 16, 25, and #17. Pump Rate Range: 0.03 to 24.3 ml/min.
- **Three Masterflex Easy-Load II (77201-60) adjustable occlusion pump heads with 160-RPM motor**, accommodates thin-walled (0.060") pump tubing: #13, 14, 16, 25, and #17. Pump Rate Range: 0.5 to 554 ml/min.
- **Three Masterflex Easy-Load II (77201-62) adjustable occlusion pump heads with 600-RPM motor**, accommodates thick-walled (0.090") pump tubing: #15, 24 and #35. Pump Rate Range: 59 to 2,258 ml/min.
- **Pressure Sensors:** Accommodates up to three (3) SciPres™ Disposable pressure sensors: P1, P2, and P3. Pressure control is achieved by modulating pump output. The user selects P1, P2 or P3 as the controlled pressure.
- **Pressure Displayed** with a resolution of 0.1 psi; choice of **bar, psi, kpa**.
- **Pressure Range:** The default pressure range of the sensors is **0-60psi**, and is calibrated at the factory. Most peristaltic pumps generate pressures up to 40 psi. If you have need for higher pressures, contact Scilog Customer Service for assistance.

Electrical:

- **Power:** 90 - 264 V~, 47-63 Hz, 75 VA, listed Class 2 switching power supply; double fused: 1A-T, 250V (CE: IR35A 250V~).
- **Operational Range:** 4 to 40° C.
- **Motor:** Choice of three (3) motors: 8, 160 and 600 RPM at 30V ---, 3.8 Amperes, Variable Pump Speed optically encoded, servo-controlled motors.
- **Encoder:** 100 lines/rev. for 600-RPM motor. 120 lines per/rev. for 8 and 160-RPM motors.
- **I/O Ports:**
- **"Printer"**, Female DB9 connector for data collection with Printer or PC.
- **"S1"**, Male DB9 connector for RS-232 connection to an electronic scale.
- **"S2"**, Male DB9 connector for RS-232 connection to an electronic scale.
- **"S3"**, Male DB9 connector for RS-232 connection to an electronic scale.
- **"External I/O"**, Female DB37 connector used for remote On/Off control of FilterTec Plus via footswitch, or for Analog interface with 4-20 ma sources, A1, A2, A3.
- **"V"**, Female DB15 connector, Not utilized on FilterTec Plus.
- **"Temperature"**, 2 pin Conxall connector for SciTemp™ disposable Temperature Sensor.
- **"P1, P2, P3"**, RJ11 connectors used for SciPres disposable Pressure Sensors.
- **"USB"**, USB-A connector, used for RS-232 data collection with a PC.
- **"Ethernet"**, RJ-45 connector, used for Modbus TCP/IP connection with system. (when available)
- **Display:** Two line LCD, 20 characters each, back-lit.
- **Data Entry:** Membrane keyboard with auditory feedback.

FilterTec Plus Balance

- Balances with capacity of 2,000 grams x 0.01 g resolution included with FilterTec Plus CP-8
- Balances with capacity of 8,100 grams x 0.1 g resolution with all other FilterTec Plus models.
- Larger balances available upon request. Contact SciLog Customer Service.

FilterTec Plus Software

Main menu with five operational modes:

- **Constant Rate Mode:** Pumps at a user defined rate, and can switch to a user defined pressure with five, user-definable alarms, in particular the **Pmaintain** Alarm that switches from Rate to Pressure control.
- **Constant Pressure Mode:** Pressure controlled flow rate is varied to maintain a user-defined pressure by modulating the Feed Rate, with five, user-definable alarms.
- **Programmable R-P Mode:** Programmable step-by-step variable Rate and Pressure control, with access to a six-way valve.
- **Setup Mode:** Selection of user preferences and interface options.
- **Manual Mode:** Manual control of motor speed and will monitor one pressure, no alarms.
- **Can change the Rate or Pressure on the fly.** This is a very useful tool in determining the optimum parameters for your process.
- **Optimizes DEF Applications:** Dead End, Direct Flow, or Normal Flow Filtration.
- **Implement Filterability Studies,** in addition to Filter Size Determinations.

Documentation Software for PC

SciDoc Excel Spreadsheet with custom macros and WinWedge interface software for data compilation. Sent to you ready to use.

- Complete process analysis with graphing of data.
- Real-time verification and documentation of process parameters.
- Includes graphs of:
 - Feed Rate (FF), Collection Rate (C1) and Pressure (P1) vs. Time
 - Collection Rate (C1) and Filtrate Quantity (Q1) vs. Time
 - T/W vs. Time, Vmax

Display, Printout and Excel Abbreviations:

MT = Military Time, HH:MM:SS
RT = Run Time, 00:00:00 at START
Q1 = Filtrate Quantity collected
P1 = Pressure at Sensor 1, psi, bar or kpa
P2 = Pressure at Sensor 2, psi, bar or kpa
P3 = Pressure at Sensor 3, psi, bar or kpa
AL = Alarm, e.g. CV Cumulative Volume Alarm
HP=4, High Pressure Alarm is "Pmaintain"
LP=1, Low Pressure Alarm is "OFF"
Q1=3, Filtrate Weight Alarm is "PUMP STOP"

FF = Feed Rate, ml/min
CV = Cumulative Feed Volume, ml
C1 = Collection Rate, gr/min
CW = Clockwise Pump Direction
CCW = Counter Clockwise Pump Direction
ST = Pump Status, START, RUN, etc.
CV=1, Cumulative Volume Alarm is "OFF"
RT=2, Run Time Alarm is "ALERT ONLY"
LF=2, Low Flow Alarm is "ALERT ONLY"
RF = Response Factor

Installation of the USB Driver:

Upon connecting the FilterTec Plus to the PC via a USB cable, the following “New Hardware Wizard” window appears. Select ‘No, not at this time’ and click “Next”. The second screen

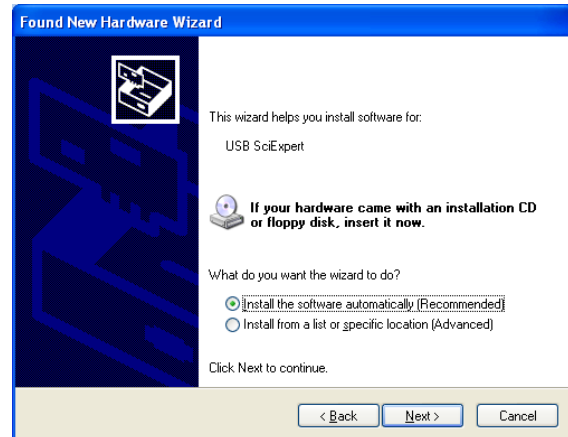

appears:

Insert the CD containing the FilterTec Plus Operating Manual into the PC, choose “Install the software automatically” and click “Next”. The following screen appears:



Choose “Continue Anyway”, and the driver will finish loading, allowing you to communicate to the FilterTec Plus via the assigned Com Port.

By opening Windows Device Manager and clicking on the + for Ports, you can determine the Com Port assigned to the FilterTec Plus. It will be listed as “USB SciExpert”. (COM8 as shown)

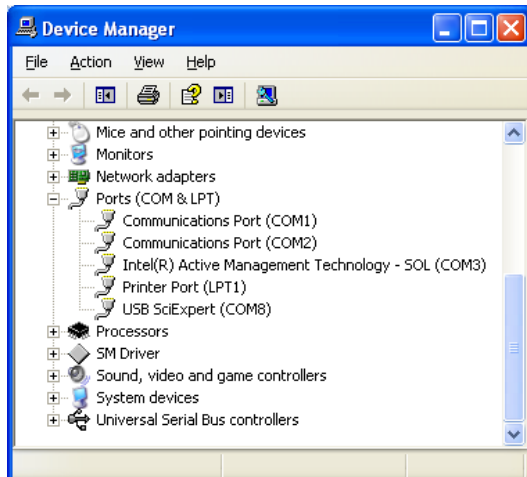

FilterTec Plus Quick Start:

The **FilterTec Plus** is shipped in conjunction with a 3-Filter Testing Station. This Station consists of 3 balances with cables, the Serial3 Balance Interface box, and a stand and clamp set for holding your 3 filters over the balances. A 6-way Rotary Valve may also be purchased with this system and its actions implemented in the Programmable R-P Mode.



This system is designed around a set of 3 matching balances, and can be configured in a couple of ways.

The first uses one head to provide solution through a manifold to 3 filters while monitoring or controlling the pressure of a single sensor, with each filter ending above its own balance, as shown below:

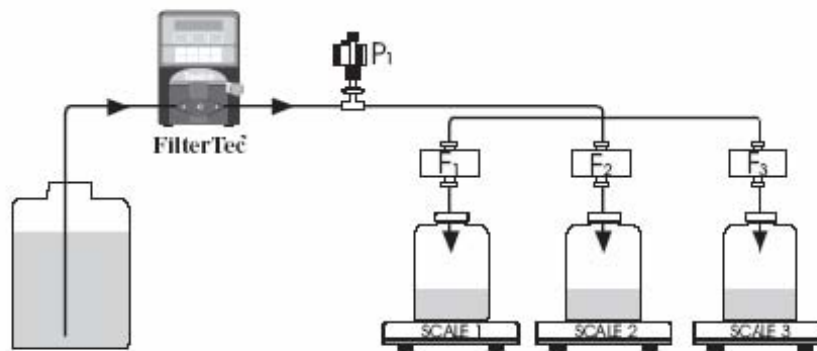

A constant pressure can be easily maintained, and the collection rates achieved will be based upon the dynamics of the filter. If the filters are the same, the Feed Rate will be roughly split into thirds.

The second multiple balance configuration utilizes 3 pump heads, 3 sets of tubing, all 3 sensors and balances, with everything running in parallel.

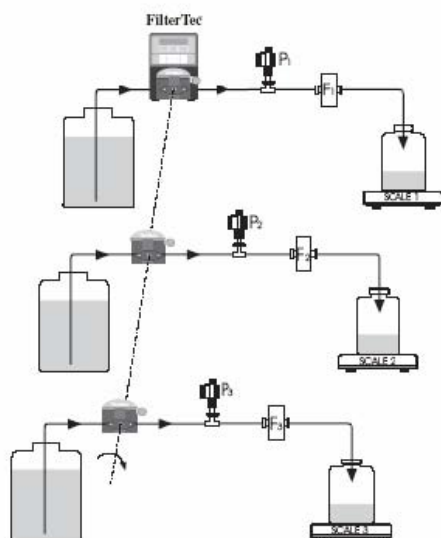

This setup puts the control of the feed rate in the hands of channel 1 with channels 2 and 3 being similar, but not always identical. To minimize differences, use tubing from the same manufacturer and lot whenever possible.

Also, while only one of the 3 sensors will be used for control, each sensor and balance will provide independent alarms based on the system's settings. When in Constant Pressure Mode, the source sensor's channel is controlled, and the other channels will be similar but not identical.

Setup:

1. Plug in and turn on all three balances and the FilterTec Plus.
2. Connect the balances to the scale ports on the FilterTec Plus, labeled S1, S2 and S3.
3. Connect all three SciPres Disposable Pressure Sensors.
4. Connect the SciTemp Disposable Temperature Sensor if using one.
5. Connect the FilterTec to your PC if collecting data, via either the Printer or USB ports.
6. Select the appropriate tubing to use for your tests. If using multiple channels, obtain enough from the same manufacturer's lot to do all the plumbing if possible.
7. Cut the tubing to the appropriate lengths required to reach from your solution reservoir through the pump head and to the pressure sensor and filter.
8. A Fittings kit is included with the FilterTec plus when shipped, and any barbed Luer connectors required can be found there. Also included are small cable ties that should be used to reinforce the barbed fittings, in particular where high pressures will be encountered.
9. Review and set the parameters of the system. Most items have usable and recommended defaults. In particular, you will need to set the Pump Rate in Constant Rate Mode and Pump Pressure in Constant Pressure Mode as they default to zero.
10. Use the Prime button to prime the tubing and wet the filters.
11. Press Exec and Run when ready to start the process and begin data collection.
12. Please refer to the FilterTec manual for descriptions of the parameters and modes.
13. SciLog strongly recommends testing and calibration of the system with distilled water or a surrogate solution prior to running your process fluids.

Part A: FilterTec Plus Hardware

1.0 Overview:

The FilterTec Plus is a DEF laboratory-scale filtration system that automates filterability studies and dead end filtration processes. In DEF, process solution is pumped through a filtration device, typically a 47mm diameter disk filter or something larger, having a user-selected porosity. In contrast to older, less efficient DEF procedures, SciLog's new "Pmaintain" Alarm method automates direct flow filtration (DFF) of dilute protein solutions while providing a 35-50%* increase in filter utilization and filtration yield. (*process solution dependant)

SciLog's new "Pmaintain" Alarm method consists of the following steps: Initially, a user-defined constant pump rate is implemented in Constant Rate Mode until a user-defined pressure limit is reached. At this point, the fluid handling system automatically switches to a constant pressure delivery, i.e. modulating the pump output until a user-defined lower filtration flow limit (collection rate) is reached and the pump automatically stops.

The FilterTec Plus system provides ease of use and operational safety: Several user definable alarm conditions can be continuously monitored and displayed.

The user defined alarms include:

- **High Pressure Alarm** to monitor filter plug-up conditions, the Pmaintain Alarm is part of this Alarm menu, will change the unit from Constant Rate to Constant Pressure at a user-defined limit.
- **Low Pressure Alarm** to monitor system leakage.
- **Low Flow Alarm** to monitor filter plug-up conditions. Used along with Pmaintain in High Pressure Alarm to terminate the filtration process.
- **Hi Temperature** to monitor the temperature of your solution.
- **Cumulative Volume Alarm** to monitor total volume based on the feed rate.
- **Filtrate Weight Alarm** to quantitatively measure the filtrate yield.
- **Run Time Alarm** that stops the pump action when a user defined filtration time has elapsed.
- **Hi and Low Analog Alarms** allow you to monitor inputs from other devices to control your process. (pH, conductivity or turbidity sensors, etc.)

All alarms provide an auditory signal; the pump stops when user defined alarm limits are exceeded. Alternatively, any alarm can be selectively disabled. All pump filtration, as well as alarm parameters can be printed out at user defined time intervals with a SciLog serial printer. Alternatively, all of the collected data can be sent to a supervisory computer for data archiving using SciDoc or HyperTerminal.

The Masterflex Easy-Load II peristaltic pump heads can accommodate PharMed and Platinum-cured Silicone pump tubing, including sizes 13, 14, 16, 25, & 17. If equipped with the larger model, sizes 15, 24 & 35 can be accommodated. Feed rates for all pump tube sizes are factory calibrated; however, the user can easily recalibrate with a single keystroke from the FilterTec Plus front panel. The pump head delivers flow rates ranging from 0.03 ml / min. to 2200 ml / min. for each of the two pump channels depending on motor rpm.

NOTE: The FilterTec Plus usually is configured with a 160-rpm motor. However, if your flow rate needs require, the FilterTec Plus is available with either a 600-rpm or 8-rpm motor. In Setup: Pump: Motor: Rpm, select the RPM of your installed motor. By doing so, the FilterTec Plus will select the appropriate factory installed calibration curves and flow rates.



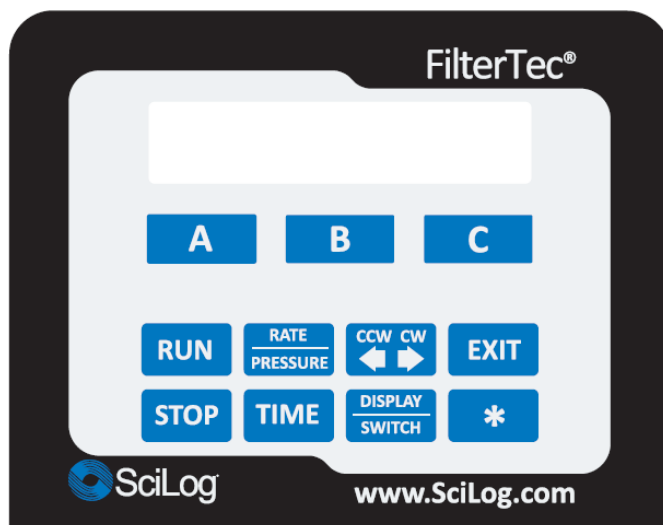





2.0 Front Panel: Data Entry & Display



The front panel consists of a user interface, which includes an alphanumeric display and a membrane keypad to select operational modes and alarm settings. The display is a two line, 20 characters each, liquid crystal display (LCD). The display is backlit to allow easy viewing over a wide range of lighting conditions.

The lower line on the LCD is used to signify the function of the “soft keys” marked “A”, “B” and “C”. The “soft key” current labels are displayed in the lower line of the LCD. If you press these keys, then the function displayed above it is performed.

The main keypad consists of eight “hard” keys whose function does not change. These keys are used for basic control and programming of the FilterTec Plus. The basic key definitions are:

-  Executes the selected operational mode and starts pump. (Run Command)
-  Interrupts current operational mode and stops pump. (Stop Command)
-  Sets pump **RATE** in ml/min, or **PRESSURE** in psi, depending on Mode being implemented. Allows “on the fly” changes in Rate or Pressure Modes.
-  Used for Time statement in Programmable R-P Mode.
-  Sets motor direction, counter-clockwise or clockwise.
-  Changes between alternate displays in all modes. (Access to TTL 1-4 in Programmable R-P Edit Mode.)
-  Exits current operational mode or menu level, stops pump.
-  Used for flow rate re-calibration. (Valve Control in Programmable R-P Mode.)

Two LED’s are also on the front panel, just to the left of the main keypad. These indicate the current pump status. A green light indicates the pump is in motion; the red light indicates that the pump has stopped.

3.0 Back Panel: Interface Options

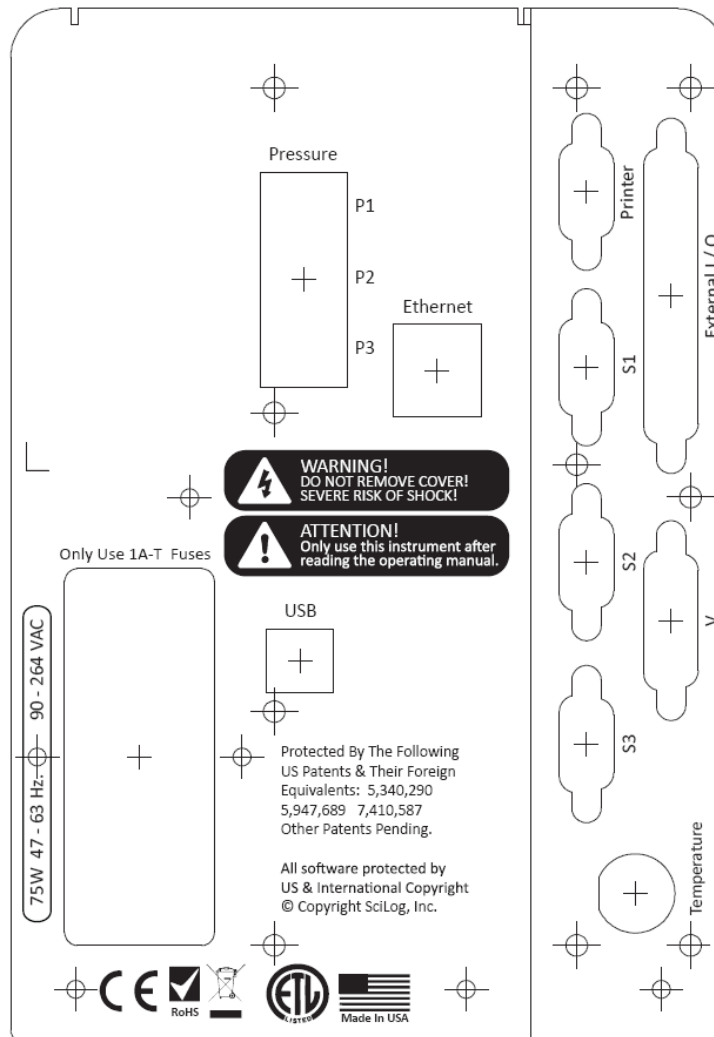

The FilterTec Plus back panel provides interfacing ports for:

- **Printer Port:** The FilterTec Plus can be connected to a PC for data collection or to a SciLog Printer via the female DB9 RS-232 port labeled "Printer". You need a SciLog RS-232 cable (P/N 080-073) to connect to a PC for data archival, or a printer cable (080-096) to make the connection between the printer and the FilterTec Plus.
- **Electronic Balances:** Male DB9, labeled "S1", "S2" and "S3".
- **Foot Switch (P/N: 080-059):** Male DB37, Labeled "External I/O".
- **SciPres Disposable Pressure Sensors:** 3 RJ11 telephone jacks, one for each pressure sensor. Labeled "P1, P2, P3".
- **SciTemp Disposable Temperature Sensor:** Conxall 2 pin connector. Labeled "Temperature".

- **External I/O Connector:** DB37 connector used to interface with various devices, allowing up to three 4-20 ma Analog inputs (A1, A2 & A3) for recording data or alarming based upon that data. It also allows an interface with SciLog foot switch (P/N: 080-059) and allows remote Start / Stop control of the FilterTec Plus.

For pin configuration, consult the drawing on this page. The DB37 port at the back panel provides three analog input channels for devices providing loop power:

- **Analog channel 1** (pin 7 signal, pin 25 ground)
 - **Analog channel 2** (pin 5 signal, pin 23 ground)
 - **Analog channel 3** (pin 2 signal SG3, pin 21 common)
- When a Footswitch or External Run / Stop Cable is desired, Pins 19 and 37 are used.

Pin out of DB37 External I/O Connector on Rear Panel:

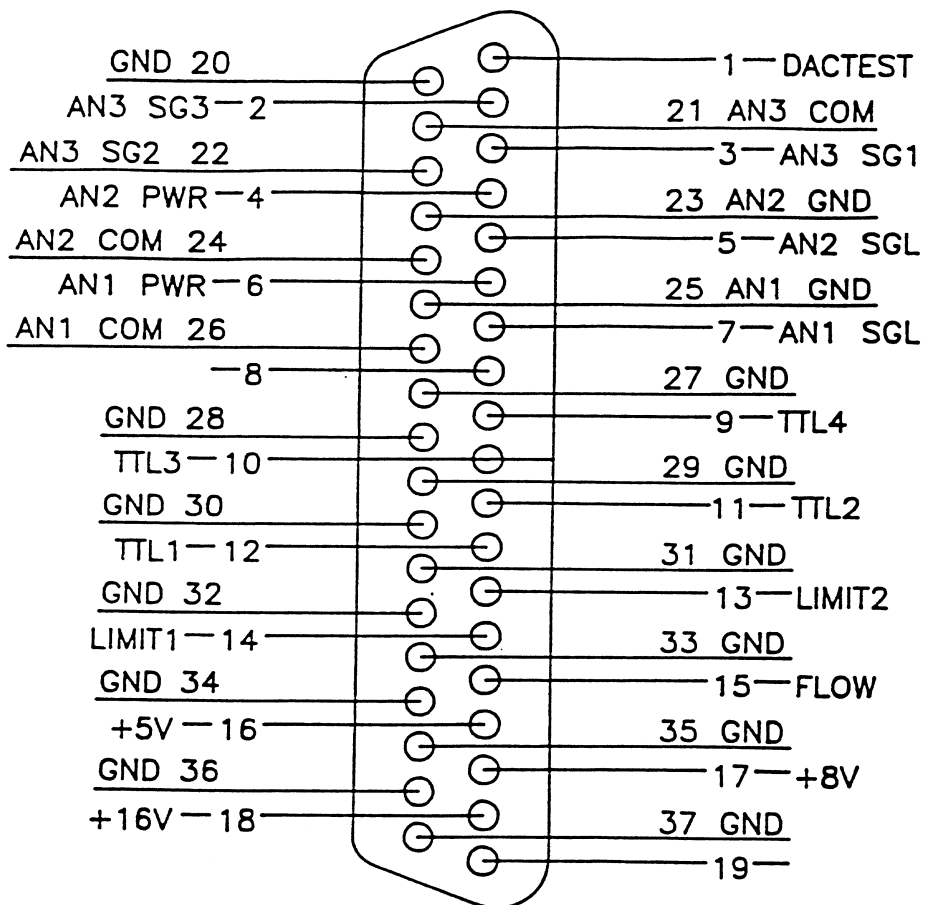

4.0 Pressure Sensor Installation:

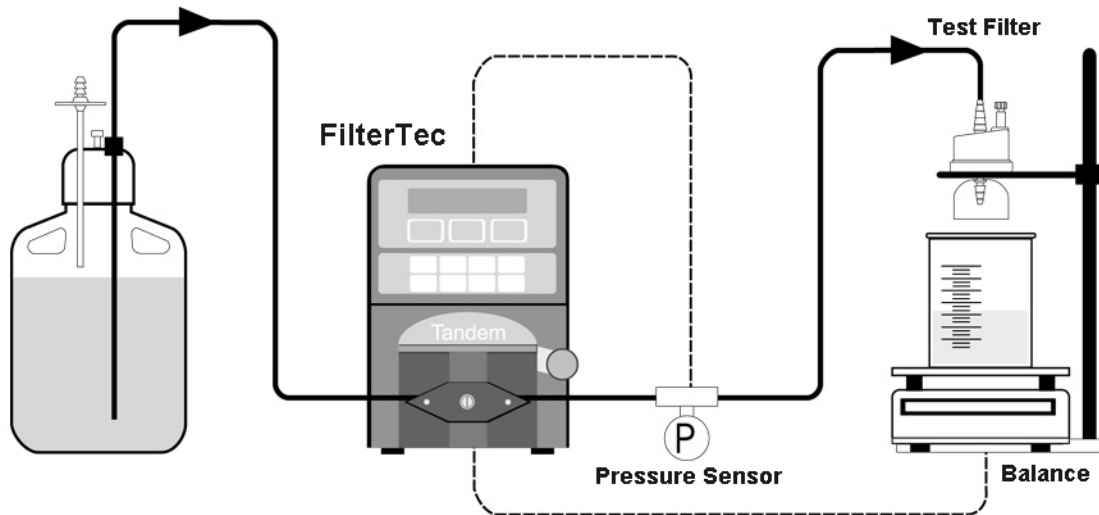

The SciPres Disposable pressure sensors are flow-through devices, and are available in 5 different sizes. Luer units ship with the FilterTec Plus under normal situations, but they are available in 3/8" and 1/2" hose barb, as well as 3/4" and 1.0" Ladish TC styles.



CAUTION: Make sure you have secured all of the connecting tubing for the pressure sensors with Nylon cable ties. At least one of the pressure sensors and tubing are located at the high-pressure side of your filtration system!

The SciPres Disposable Pressure Sensors plug into telephone jack connections on the rear panel of the FilterTec Plus with the cables provided. The connections are **labeled "P1", "P2" and "P3"** for ease of use. When testing filter trains, all three sensors can be monitored at the same time.

The SciPres Disposable pressure sensors are easy to change when the need arises, and are readily available from SciLog in packs of 5. They may be sanitized using several methods, CIP with NaOH or alcohol, autoclaved up to twice, or gamma irradiated. (Only those with grey rings around the connector are gamma stable.)

Part B: FilterTec Plus™ Software

1.0 MAIN MENU

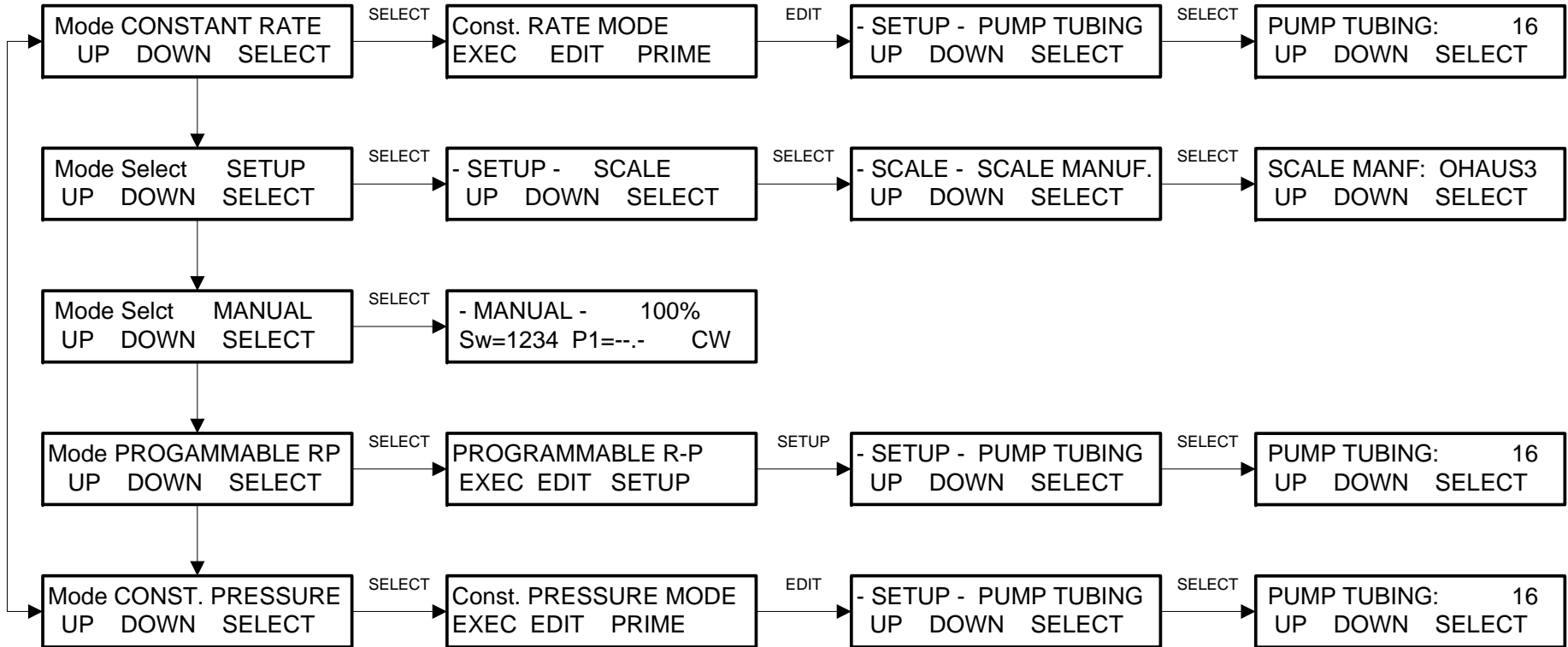

1.0 Software Overview: Main Menu

The FilterTec Plus main menu consists of **five (5) operational modes** as shown on the previous page. Use the “**Up**” and “**Down**” keys to scroll through the main menu. Press the “**Select**” key to enter a chosen operational mode, i.e. CONSTANT RATE. Pressing the “Select” key enters the 1st submenu level, which provides access to the “**Exec**”, “**Edit**”, and “**Prime**” functions in most modes. In the “Edit” submenu, the pump parameters are selected. In the “Exec” submenu, the parameters chosen under “Edit” are executed. The “Prime” key runs the pump when the key is held down to ‘prime’ the system and removes the air bubbles when needed. Press the “**Exit**” key to return to the main menu. Pressing “Exit” repeatedly will always return to the top of the menu.

CONSTANT RATE Mode: This operation mode allows implementation of a **Constant Rate / Constant Pressure Filtration**, i.e. a user selected rate (filtration feed rate) is maintained during the initial phase of the filtration. If the “**Pmaintain**” alarm is enabled, the unit will change from constant rate to constant pressure control at a user defined pressure level. In the “Edit” submenu first select the pump tubing you want to use in your application. Based upon your **tube size selection**, the FilterTec Plus will access factory installed calibration tables, which relate the pump output in ml/min. to pump motor speed. Please note: the flow rate calibration data can be updated by the user utilizing the star (★) key. This provides simple modification of the factory-installed data for a particular motor/pump head/tubing combination.

Several user-programmable Alarms can be selected: Cumulative Volume; Hi Temperature; Run Time; Lo-Pressure; Hi-Pressure; Filtrate Weight, or Low-Flow.

Each alarm can be: 1. Off (Disabled), 2. Alarm Only (Provide auditory alarm), or 3. Stop Pump (Provide an auditory alarm and stop), and are triggered when alarm limits are exceeded. The Hi-Pressure alarm has one additional option, 4. Pmaintain, which changes from rate to pressure control at a user defined limit. The FilterTec Plus simultaneously monitors and displays up to three line pressures needed for filter train evaluation as provided by the three SciPres Disposable pressure sensors. The Hi and Low Pressure alarms relate to the pressure sensor chosen as the “Pressure Source” as defined in the SETUP: Pump, Press Sensor submenu

At user-defined intervals, all filter/pump parameters can be printed out or send to a PC for archiving. Print parameters are set in the SETUP: Printer. The balance allows quantitative filtrate collection by weight, use of the Filtrate Weight alarm mentioned above, along with the display and printout of the Collection Rate.

CONSTANT PRESSURE Mode: This operation mode allows you to implement **Constant Pressure Filtration**, i.e. a user selected filter backpressure is maintained by modulating the pump output. When the filtration device starts to plug up, the FilterTec Plus will maintain the selected filter backpressure by automatically decreasing the feed rate. The FilterTec Plus simultaneously monitors and displays up to three line pressures as provided by the 3 SciPres disposable pressure sensors. The process can be controlled by any one of the 3 line pressures as selected by the user in the **SETUP: Pump, Press Sensor; Source** submenu. The filter backpressure setting, **Pump Pressure**, is selected in the “Edit” submenu. This setting allows you to choose a safe backpressure that also is consistent with a desired filtrate flow rate.



NOTE: All Alarm, Print and Balance parameters are the same as discussed in CONSTANT RATE Mode, except for the replacement of the Hi-Pressure Alarm with a Low-Flow Alarm.

PROGRAMMABLE R-P Mode: This mode allows you to implement variable Feed Rates or Pressure Rates that change over time in a Stepped (immediate change) or Scanned (ramped) manner. This is accomplished by entering step-by-step instructions from the FilterTec Plus front

panel buttons. You can enter and control by using Run, Stop, Time, Direction, R-Step, R-Scan, P-Step, P-Scan, V, and W commands to have the system perform changing rates and pressures, even rotary selector valve positions for switching buffers or collection vessels. A sample program is included in this manual. All alarms used in CONSTANT RATE and CONSTANT PRESSURE Modes except Run Time are available in PROGRAMMABLE R-P Mode.

SETUP: This operational mode allows you to select various user preferences and interface options. The **Setup: Scale** submenu provides electronic balance options. Balances that can interface with the FilterTec Plus must have bi-directional serial communication, and NOT have internal calibration or be “delta-range” models. Many Mettler, Ohaus, and Sartorius balances can be used. The **Setup: Clock** submenu allows the user to set the time and date used in the display. The **Setup: System Test** submenu allows checkout of FilterTec Plus outputs and requires purchase of a special set of connectors to perform the test. **Setup: Test Mode** provides an additional mode to test the I/O’s independently. **Setup: Ethernet** is used to set the IP Address, Subnet Mask, and Gateway for Modbus TCP/IP communications. **Setup: Printer** is used for setting up the printer/PC communications parameters as well as print time interval and the print delay. **Setup: Analog** defines the ranges, alarms and limits for the three analog channels available for data acquisition and reporting of 4-20 ma signals from detectors equipped with analog outputs. **Setup: Temperature** allows the input of an offset value if needed for the temperature input. **Setup: Press. Sensor** is used to zero the pressure sensors, set the units (psi, bar, kpa), and choose the source for the pressure control and alarms. **Setup: Pump** allows you to set various pump user preferences, most importantly the Motor RPM. **Setup: Scale2** and **Scale3** are similar to Scale mentioned above.

MANUAL: Allows manual control of pump speed and direction, and will display the value of sensor P1. This is very useful for initial testing to determine flow rate / pressure settings.



NOTE: CONSTANT RATE, CONSTANT PRESSURE, and PROGRAMMABLE R-P mode Alarms and Printer parameters are not functional in the Manual mode.

2.0 CONSTANT RATE MODE

Constant Rate / Constant Pressure Filtration: Edit Menu

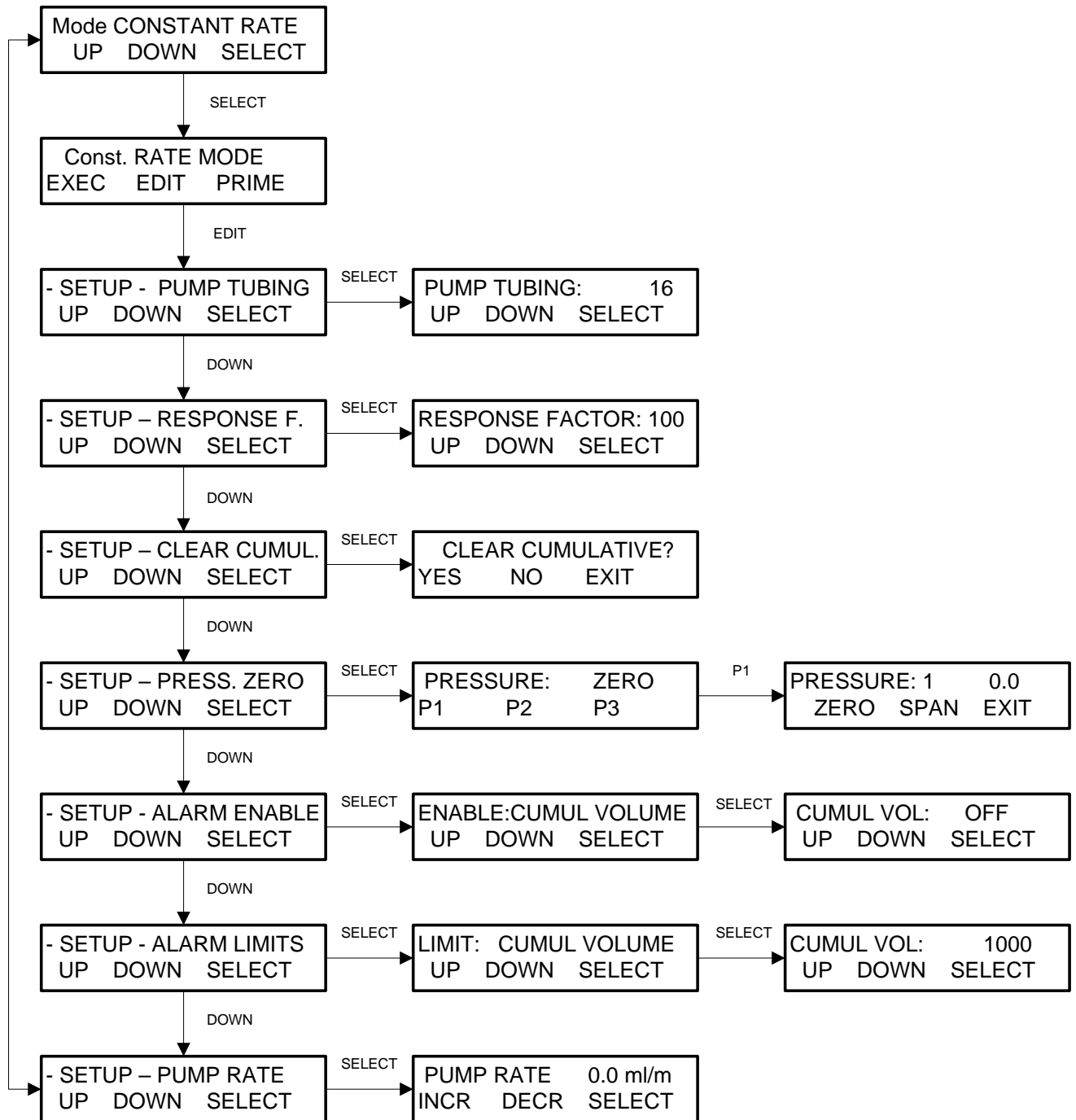

2.0 CONSTANT RATE Mode: Constant Rate/ Pressure Filtration.

SUMMARY: In this mode the selected pump rate (**filtration feed rate**) is maintained throughout the filtration process. The FilterTec Plus can then switch to a user selected **constant filtration pressure**. The **Pmaintain** setting is chosen in the Alarm Enable: Hi-Pressure submenu to cause this to occur. First select the **pump tube size** (#13, 14, 16, 25, 17, 15, 24, or 35) (Note: the use of #18 is not recommended), and then select the **pump rate** in terms of ml/min, then set the Hi-pressure Limit to the desired constant pressure. The FilterTec Plus feed rate can be re-calibrated by the utilizing the front panel star (★) key. (If you have changed the motor sub-assembly from the factory installed one, select the correct RPM of your new motor in SETUP: PUMP: Motor RPM submenu. (The choices are 8, 160 or 600-RPM.)

Use “**Up**” and “**Down**” keys to make a selection, then press, “**Select**” to implement that selection.

Pump Tubing: Select sizes #13, 14, 16, 25, 17, 15, 24, or #35, using “**Up**” and “**Down**” keys for choice of pump tubing size, then press “**Select**”. Based upon **selection**, the FilterTec Plus accesses factory installed calibration curves, which relate the pump output in ml/min. to pump motor speed.

Response F: Response Factor setting. The Pump Response Factor = 100 is the default value. Decreasing this Pump Response Factor will decrease the pumps responsiveness to pressure changes.

Clear Cumul: Resets (Clears) the following counters in the system: CV = Cumulative Volume; RT = Run Time; Q1 = Filtrate Weight.

Pressure Zero: Allows you to zero the filter backpressure reading for all 3 SciPres Disposable pressure sensors, P1, P2 and P3. **The FilterTec Plus must not be running when resetting pressure sensor output, and the sensor must be plugged in.** Do not use the SPAN key unless instructed to do so by SciLog Customer Service. This is used to calibrate the pressure sensor output, and requires additional hardware.

Alarm Enable: Allows you to select alarm options for several alarm conditions. Four options are available: 1. **Off** (Disable the Alarm); 2. **Alarm Only** (Enable an auditory alarm); 3. **Pump Stop** (Stop the pump and provide an auditory alarm); or 4. **PMaintain** which switches the FilterTec Plus from Rate Control to Pressure Control at a user-defined limit and maintains that pressure by adjusting the system’s motor speed.

NOTE: PMaintain only exists as an option for the Hi-Pressure Alarm.

Alarm Limits: Used to assign alarm limits for several alarm conditions:

Cumulative Volume in milliliters;

Low-Flow in ml/min;

Hi-Temp in degrees Celsius;

Run Time in Hours: Minutes;

Lo-Pressure (monitor system leakage) in psi;

Hi-Pressure (filter backpressure) in psi;

Filtrate Weight in grams. (This alarm must be enabled in order to obtain and display the Filtrate Weight (Q1), and several values calculated from it.)

Hi and Lo-Pressure alarms are related to the Pressure Source chosen in SETUP: Press.

Sensor, Source. The Alarm condition is triggered when alarm limit is exceeded. Alarms are not mutually exclusive. You may select any combination of alarms.

Pump Rate: Select pump rate in terms of **ml/min**, however first select pump tube size, see 2.1. Pump Rate may be changed “on the fly” by pressing the Rate / Pressure key on the front panel, making the change, and pressing ‘Select’.



2.1 Pump Re-calibration:

The FilterTec Plus contains a permanent calibration table for each of the nine (9) tubing sizes: 13, 14, 16, 25, 17, 15, 24 & 35. For a given pump tube size, the calibration table relates the pump motor RPM with the pump output in terms of ml / min. However, the user can update the FilterTec Plus pump calibration very easily. (Note: the use of #18 tubing is not recommended)



NOTE: The FilterTec Plus usually is configured with a 160-rpm motor, and uses the built-in calibration curves for that motor.

If flow rate needs require, the FilterTec Plus is also available with either a 600-rpm or 8-rpm motor. In order for the FilterTec Plus to properly display the correct flow rates and cumulative volume when using these motors, access SETUP: PUMP: Motor RPM and select the appropriate RPM for the installed motor. The FilterTec Plus will then implement the factory installed calibration curves for that particular motor.

(This will have been done for at the factory prior to testing and shipping, and should only need to be changed if a different motor subassembly is purchased and installed.)

In order to use this recalibration feature, first select (in **EDIT**) the pump tube size in use, e.g. size #17, then select the pump rate, e.g. 250ml/min. Press the **EXIT** key and then the **EXEC** key. FilterTec Plus will now show the following display:

SET: T17 PR: 250ml/m Press RUN when Ready
--

With the tubing primed, the system is ready to recalibrate the #17 pump tubing. For calibration purposes, pump water into a container, e.g. 1000grams, placed onto a top-loading balance with no filter attached. Alternatively use a 1000ml volumetric flask.

Press the **RUN** key and begin dispensing. Press the **STOP** key (not **EXIT**) to stop pumping when 1000 grams have been dispensed. Press the **Star (★)** key and the following display will be shown:

DV:1000	AV:1000
Incr.	Decr. Select

Adjust (increase or decrease) the AV (Average Volume) parameter to 1000, or whatever the actual dispensed weight is, press **Select**, the calibration table for #17 pump tubing will be updated.

Important: The selected calibration volume or weight should be 4+ times the selected pump rate or greater. For example, if the selected pump rate is 250 ml/min. the minimum calibration volume / weight should be between 1000 mls or grams.



Note regarding this and SciDoc: The FilterTec Plus system contains volumetric calibration curves for various motor/head/tubing combinations that are factory installed. This value is displayed and output to SciDoc as FF. In most cases the Pump Rate (FF) is merely a starting or reference point, and the weight related data, Q1, & C1 are of greater importance. These are measured values of the Filtrate Weight Collected (Q1) and Collection Rate (C1), and are used in the Vmax data and Chart that are included in the SciDoc spreadsheet.

2.2 CONSTANT RATE MODE

Constant Rate / Constant Pressure Filtration: Alarm Limits Menu

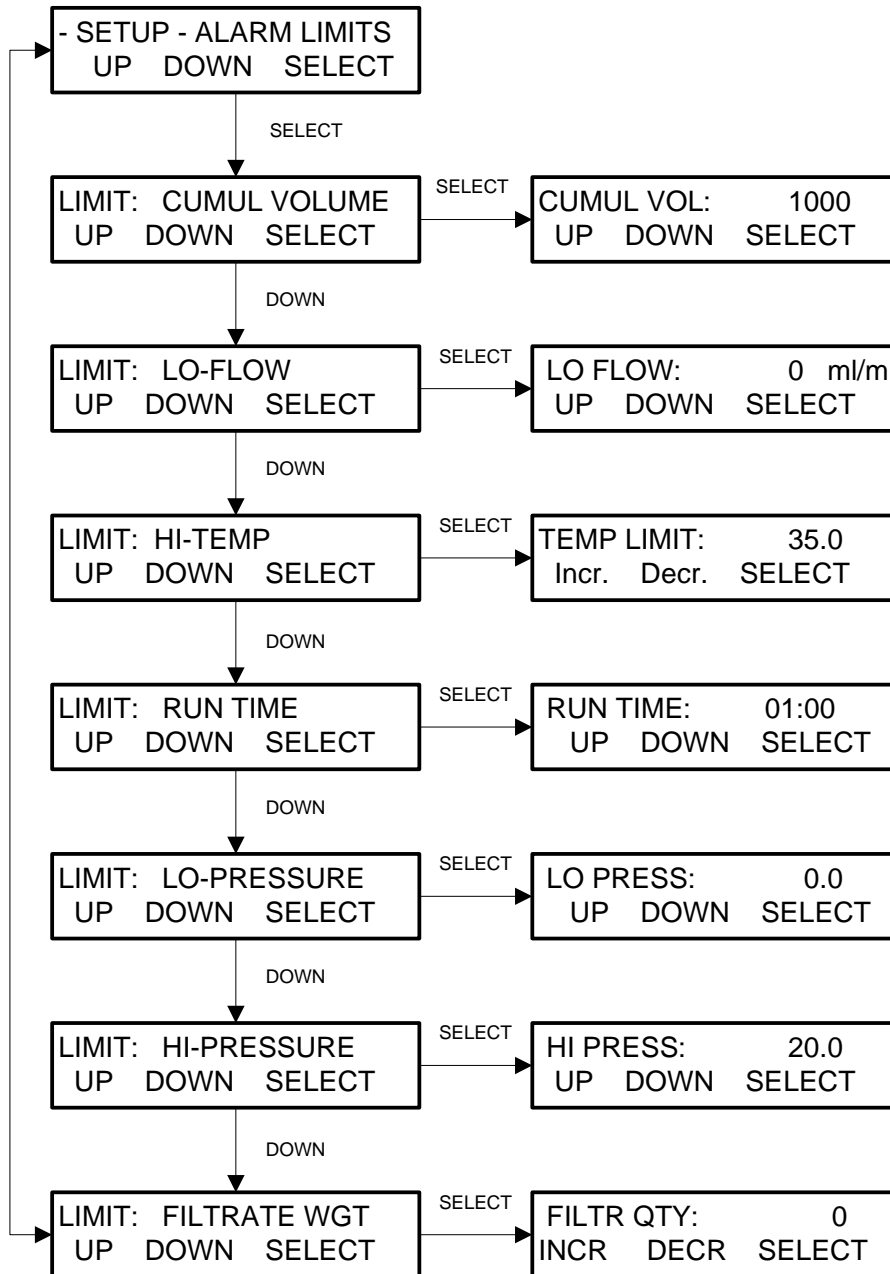

2.2 CONSTANT RATE Mode: Alarm Limits

SUMMARY: This section allows the assignment of limiting values for several alarm conditions: **Cumulative Volume (CV)** (based on feed rate) in ml; **Lo-Flow (LC)** (based upon collection rate in ml/min; **Hi-Temp (HT)** in °C; **Run Time (RT)** in Hours: Minutes; **Lo-Pressure (LP)** (monitor system leakage) in psi; **Hi-Pressure (HP)** (filter back pressure) in psi; **Filtrate Weight (FQ)** in grams. **Note: The alarm condition is triggered when the alarm limit is achieved.** Alarms are not mutually exclusive. You may select any combination of alarms. For critical alarms (i.e. Lo-Flow Alarm) you want the FilterTec Plus pump to stop (**Pump Stop**), for less critical alarm conditions you may want to choose an auditory alarm (**Alarm Only**). Each alarm may be disabled if not required.

Use “**Up**” and “**Down**” keys, then press “**Select**” to implement.

Cumulative Volume (CV): This alarm setting represents the total volume of process solution (based on the feed rate) that is delivered when a balance is not in use. Use the Filtrate Weight Alarm for this purpose if you are using a balance! For example: if you set the Cumulative Volume Alarm to 10,000ml or 10 liters, the FilterTec Plus will either alarm and/or stop the pump when 10 liters of filtrate has been sent through the filtration device. Default = 1000.

Lo-Flow (LC): At the end of the Constant Pressure portion of the process, this represents a critical alarm condition. The FilterTec Plus will automatically decrease the pump rate to maintain the selected Hi-Pressure Limit setting once the Pmaintain alarm has been triggered. The Lo-Flow parameter (ml/min) represents lowest collection rate before the pump shuts down, and is based on the collection rate (C1) when a balance is used and the Feed Rate (FF) without a balance. Default = 0.

Hi-Temp (HT): Used to monitor the temperature of the process solution, this will stop the pump at the set limit. Default = 35.0 °C

Run Time (RT): This alarm setting allows you to set a timer for the filtration of your process solution. For example, if you set the Run Time Alarm to 01:30, then the FilterTec Plus will provide an auditory alarm and / or stop the pump after one (1) hour and thirty (30) minutes have passed. Default = 01:00.

Lo-Pressure (LP): Typically set 3-5 psi units below the Hi-Pressure setting. The Lo-Pressure Alarm is triggered when a sudden filter backpressure drop occurs after rising above this setting. Such a change in the filter backpressure usually indicates a significant system leak. This is a critical alarm, set to Pump Stop. Default = 0.0.

Hi-Pressure (HP): If you have chosen the Pmaintain in Alarm Enable, this is the value at which the pump will change from the Constant Rate method to the Constant Pressure method. Setting the Alarm to Pump Stop creates a Constant Rate only process that will stop when the Hi-Pressure Limit is achieved. Default = 20.0 psi.

Filtrate Wgt. (FQ): The FilterTec Plus comes with a top-loading balance. Enter the filtrate weight (grams) that you want to collect, and the FilterTec Plus will either alarm or stop the system when the desired weight has been collected. Set this value beyond the balance capacity if you do not wish it to trigger during normal use. (If the balance goes negative at the start of the run, the 0 gm default could trigger this alarm.)



Note: This alarm must be enabled to at least “Alarm Only” in order for the Q1 (Filtrate Quantity) to be obtained or displayed. Default Limit = 0.

2.3 Constant Rate: Const. Rate / Const. Pressure Filtration; Execute Display

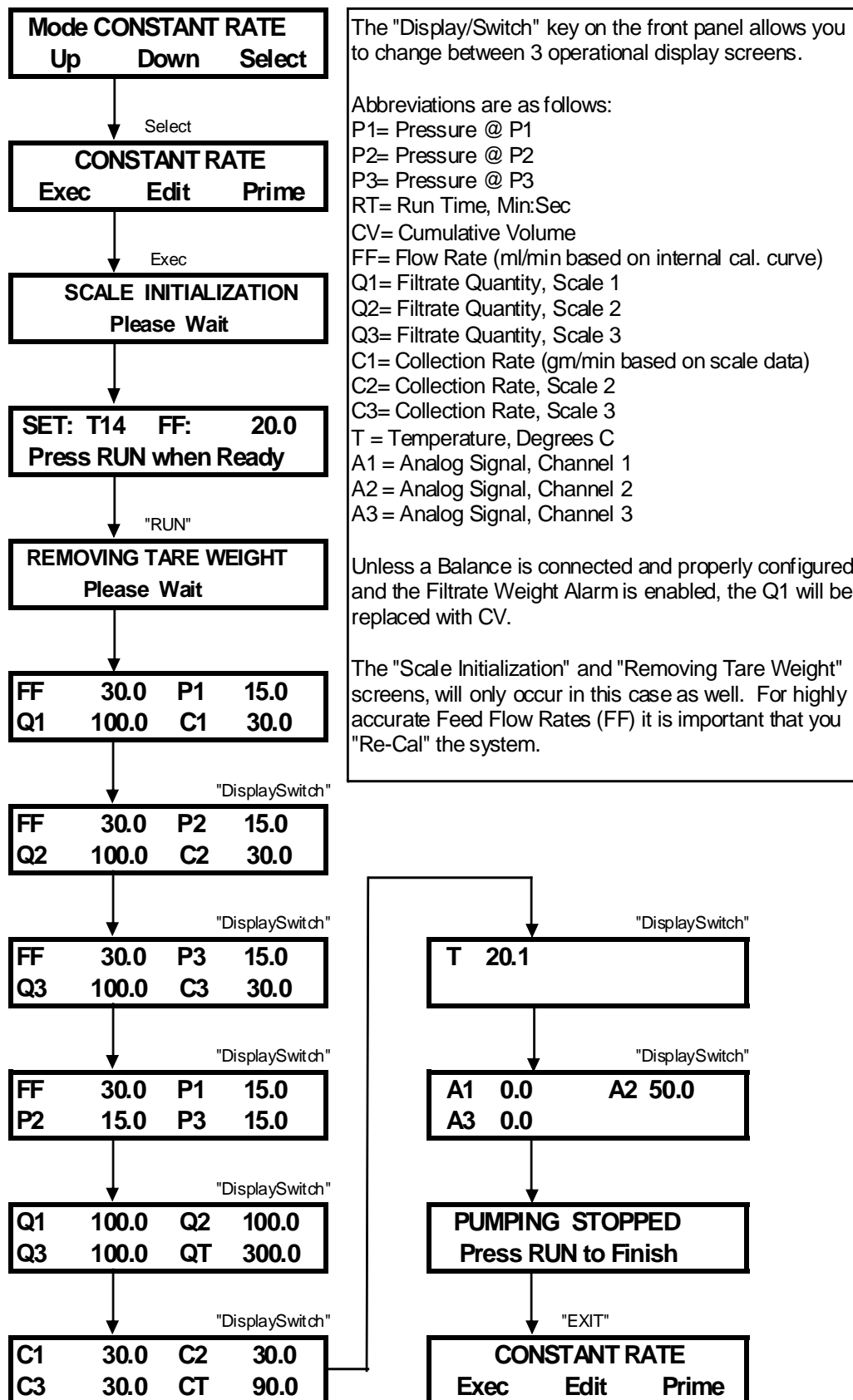

The "Display/Switch" key on the front panel allows you to change between 3 operational display screens.

Abbreviations are as follows:

- P1= Pressure @ P1
- P2= Pressure @ P2
- P3= Pressure @ P3
- RT= Run Time, Min:Sec
- CV= Cumulative Volume
- FF= Flow Rate (ml/min based on internal cal. curve)
- Q1= Filtrate Quantity, Scale 1
- Q2= Filtrate Quantity, Scale 2
- Q3= Filtrate Quantity, Scale 3
- C1= Collection Rate (gm/min based on scale data)
- C2= Collection Rate, Scale 2
- C3= Collection Rate, Scale 3
- T = Temperature, Degrees C
- A1 = Analog Signal, Channel 1
- A2 = Analog Signal, Channel 2
- A3 = Analog Signal, Channel 3

Unless a Balance is connected and properly configured, and the Filtrate Weight Alarm is enabled, the Q1 will be replaced with CV.

The "Scale Initialization" and "Removing Tare Weight" screens, will only occur in this case as well. For highly accurate Feed Flow Rates (FF) it is important that you "Re-Cal" the system.

3.0 CONSTANT PRESSURE MODE

Constant Pressure Filtration: Edit Menu

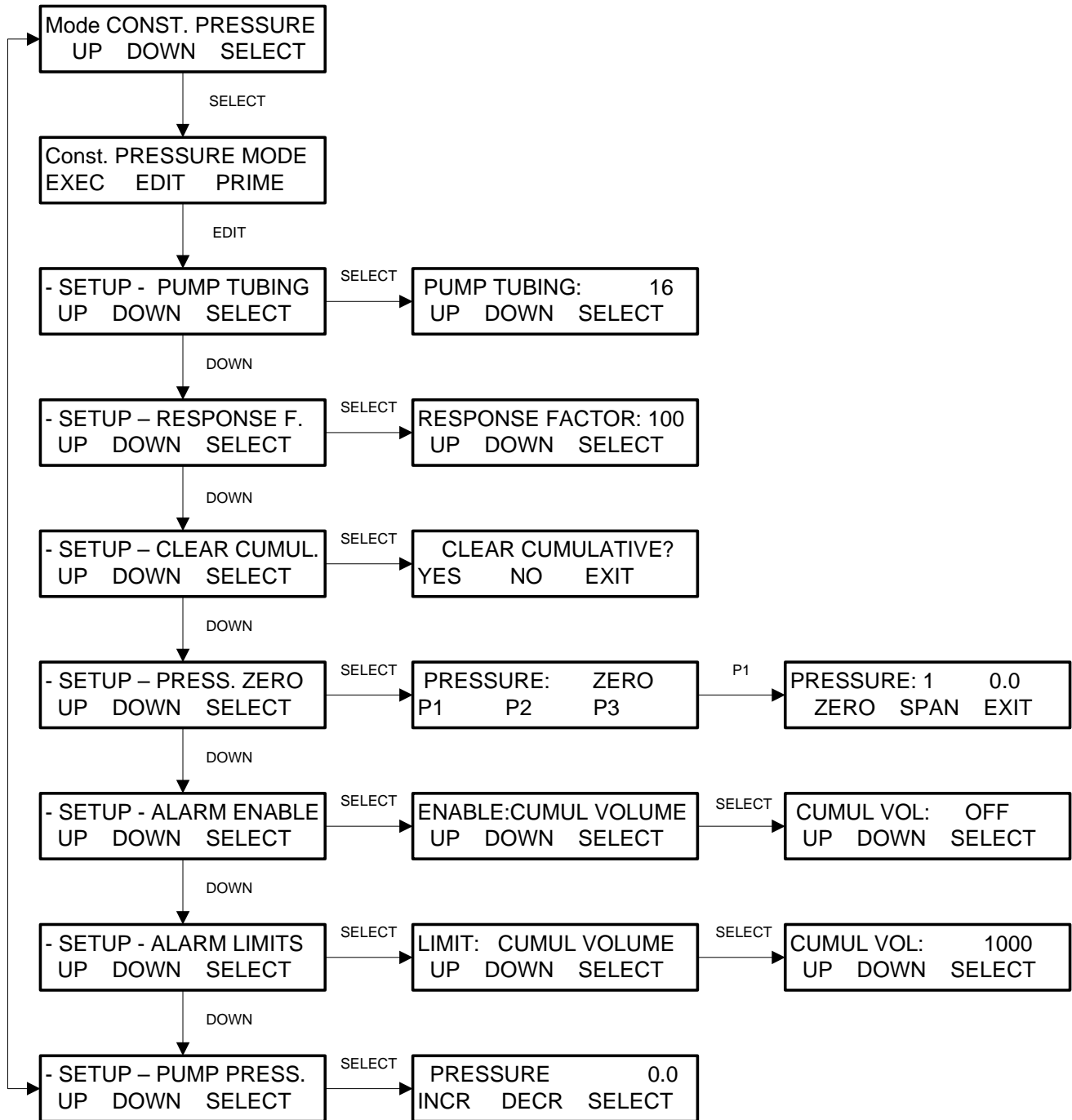

3.0 CONSTANT PRESSURE: Constant Pressure Filtration

SUMMARY: This FilterTec Plus mode allows implementation of a **constant pressure filtration**, i.e. a user selected filter backpressure is achieved and maintained throughout the filtration process. When the filter device starts plugging up, the FilterTec Plus detects a corresponding increase in filter backpressure. In order to maintain the selected filter backpressure setting, **the FilterTec Plus will automatically decrease the feed rate**. Thus the constant pressure function of the FilterTec Plus allows use of a safe backpressure setting that is consistent with a high filtrate flow rate.

This mode is also used to run Vmax tests for filter sizing tests.

Use “**Up**” and “**Down**” keys, then press “**Select**” to implement that selection.

Pump Tubing: Select sizes #13, 14, 16, 25, 17, 15, 24 or #35, use “**Up**” and “**Down**” keys for choice of pump tubing size, then press “**Select**”. Based upon selection, the FilterTec Plus will access factory installed calibration tables, which relate the pump output in ml/min. to motor speed. FilterTec Plus output can also be re-calibrated by the utilizing the front panel star (★) key. (See Constant Rate Mode for information on flow rate calibration.)

Clear Cumul: Resets (Clears) the following counters in the “Exec” front panel display: CV = Cumulative Volume; RT = Run Time; Q1 = Filtrate Weight.

Response F: Response Factor setting, 1 to 100. Increasing the Pump Response Factor will increase the pumps responsiveness. Default = 100.

Pressure Zero: Allows you to zero the backpressure readings of all 3 SciPres pressure sensors. The FilterTec Plus must not be running when resetting pressure sensor output, and the sensor must be plugged in.



Do not exceed the maximum pressure of 60 psi for the SciPres sensors or damage to the sensor may occur.

Alarm Enable: Allows you to select alarm options for several alarm conditions. There are three options available: 1. **Off** (Disable the alarm); 2. **Alarm Only** (Enable an auditory alarm); 3. **Pump Stop** (Stop pump and provide an auditory alarm). All alarms trigger when user defined alarm limits are exceeded.

Alarm Limits: Allows you to assign alarm limits for several alarm conditions:

Cumulative Volume in ml;

Hi-Temp in degrees Celsius.

Run Time in Hours: Minutes;

Lo-Pressure (monitor system leakage) in psi;

Lo-Flow (high filter backpressure) in ml/min based upon collection rate;

Filtrate Quantity in grams. (This alarm must be enabled in order to communicate with the balance.)

The Lo-Pressure and Lo-Flow alarms are related to the pressure source chosen.

Pump Pressure: Allows you to select **filter backpressure** (30psi, max. recommended) for your filtration application. The FilterTec Plus will maintain the selected setting throughout the filtration process. Pump Pressure may be changed “on the fly” by pressing the RATE/PRESSURE key on the front panel, making the change, and pressing the ‘Select’ button. **Do not exceed the pressure rating for your filtration device;** consult the the filter manufacturer specifications. Select a safe backpressure that also maximizes your filtrate flow rate.

NOTE: The Source chosen in **SETUP: Press. Sensor, Source** i.e. P1, P2 or P3; or is the pressure that will be controlled by this setting.

3.1 CONSTANT PRESSURE MODE

Constant Pressure Filtration: Alarm Limits Menu

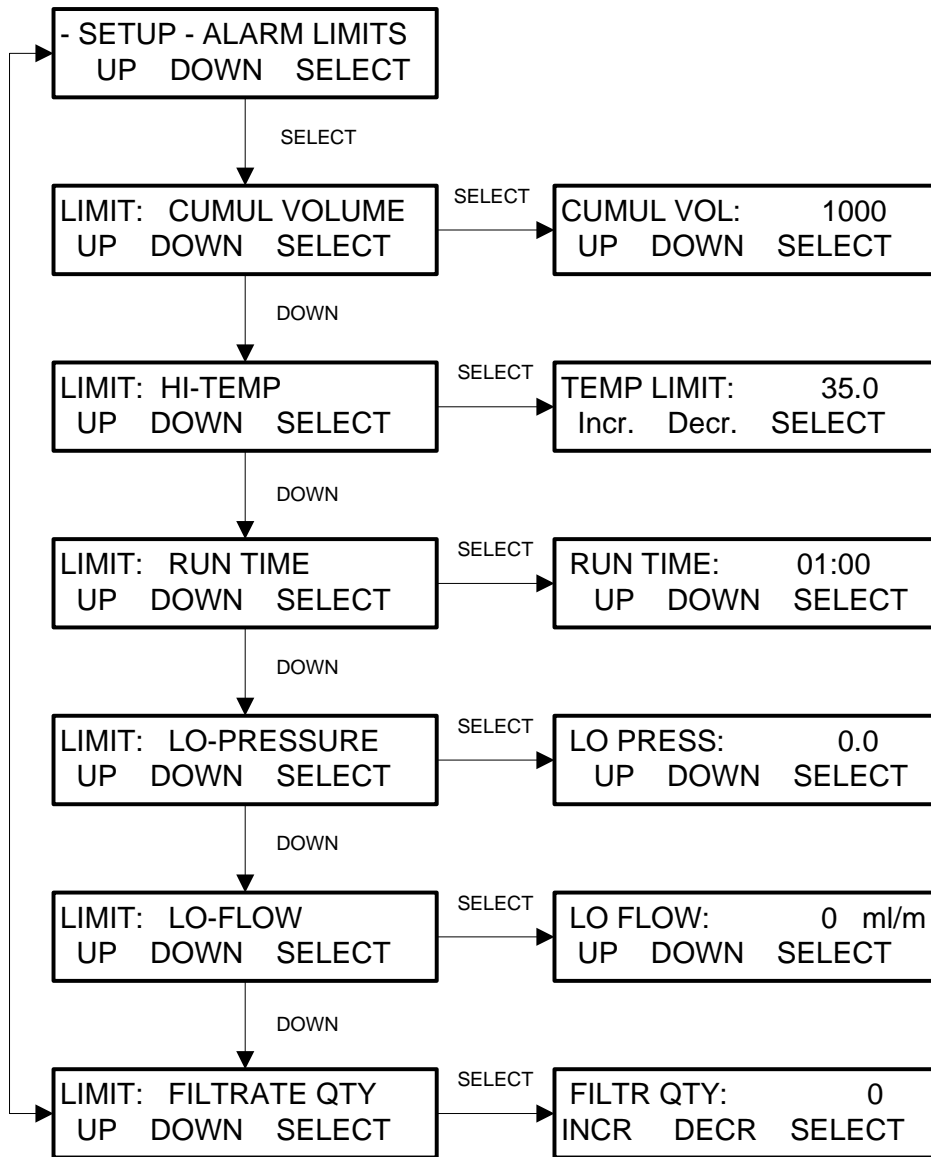

3.1 CONSTANT PRESSURE: Alarm Limits

SUMMARY: This section allows you to assign limiting values for several different alarm conditions: **Cumulative Volume (CV)** in milliliters; **Hi Temperature** in °C; **Run Time (RT)** in Hours: Minutes; **Lo-Pressure (LP)** (monitor system leakage) in psi; **Lo-Flow (LC)** (pump will stop when collection rate falls below this limit) in ml/min.; **Filtrate Quantity (FQ)** in grams. **Note: The alarm condition is triggered when the alarm limit is achieved.** Alarms are not mutually exclusive. You may select any combination of alarms.

For critical alarms you may want the FilterTec Plus pump to stop (**Pump Stop**). For less critical alarm conditions you may want to choose an auditory alarm (**Alarm Only**).



Note: The Lo-Pressure alarm is directly related to the Source chosen in SETUP: Press. Sensor, Source, i.e. P1, P2, etc.

Use “Up” and “Down” keys, then press “Select” to implement selection.

Cumulative Volume (CV): This alarm setting represents the total volume of process solution that is delivered through your filtration device when no balance is in use. **Use the Filtrate Weight Alarm for this when a balance is in use!** For example: if you set the **Cumulative Volume Alarm** to 10,000ml or 10 liters, the FilterTec Plus will either alarm and / or stop the pump when 10 liters of solution has been delivered through the filtration device.

Hi-Temp (HT): Used to monitor the temperature of the process solution, this will stop the pump at the set limit. Default = 35.0 °C

Run Time (RT): This alarm setting allows you to set a timer for the filtration of your process solution. For example, if you set the **Run Time Alarm** to 01:30, then the FilterTec Plus will provide you with an auditory alarm and / or stop the pump after one (1) hour and thirty (30) minutes have passed. This allows you to define the processing time, i.e. the time required to obtain a desired filtrate yield.

Lo-Pressure (LP): Typically set 3-5 psi units below the **Pump Pressure** setting. The Lo-Pressure Alarm is triggered when a sudden filter backpressure drop occurs after rising above this setting. Such a change in the filter backpressure usually indicates a system leak, i.e. pump tubing has slipped off the filter connection.

Lo-Flow (LC): For constant pressure filtration, this represents a critical alarm condition, and should be set to **Pump Stop** in Low-Flow Alarm Enable. In this operational mode, the FilterTec Plus will detect any filter backpressure increases in the source pressure sensor (due to slow filter plug-up) and automatically decrease the feed rate to maintain the selected **Pump Pressure** setting (see 3.17). The Lo-Flow parameter (ml/min) represents lowest pump rate before the pump shuts down. The Lo-Flow parameter should be set just below your desired minimum collection rate.

Filtrate Qty. (FQ): The FilterTec Plus comes with a top-loading balance. Enter the filtrate weight (grams) that you want to collect, and the FilterTec Plus will either alarm or stop the pump when the desired weight has been collected. Set this value to zero if you do not wish it to trigger during normal use. The maximum value is 99,999 gm. (100Kg).



Note: This alarm must be enabled in at least “alarm only” mode in order for the Q1 (Filtrate Weight) to be obtained or displayed.

Constant Pressure: Constant Pressure Filtration: Execute Display

Mode CONST. PRESSURE
Up Down Select

Select

CONSTANT PRESSURE
Exec Edit Prime

Exec

SCALE INITIALIZATION
Please Wait

SET: T16 P1: 20.0 psi
Press RUN when Ready

"RUN"

REMOVING TARE WEIGHT
Please Wait

**

FF	0.0	P1	0.0
Q1	0.0	C1	0.0

"Display/Switch"

FF	0.0	P2	0.0
Q2	0.0	C2	0.0

FF	0.0	P3	0.0
Q3	0.0	C3	0.0

"Display/Switch"

FF	0.0	P1	0.0
P2	0.0	P3	0.0

"Display/Switch"

Q1	0.0	Q2	0.0
Q3	0.0	QT	0.0

"Display/Switch"

C1	0.0	C2	0.0
C3	0.0	CT	0.0

"Display/Switch"

T	20.1		
---	------	--	--

The "Display/Switch" key on the front panel allows you to change between 3 operational display screens.

Abbreviations are as follows:

P1= Pressure @ P1

P2= Pressure @ P2

P3= Pressure @ P3

RT = Run Time, Min:Sec

CV= Cumulative Volume

FF= Flow Rate (ml/min based on internal cal. curve)

Q1= Filtrate Quantity, Scale 1

Q2= Filtrate Quantity, Scale 2

Q3= Filtrate Quantity, Scale 3

QT= Filtrate Quantity, Total

C1= Collection Rate (gm/min based on scale data)

C2= Collection Rate, Scale 2

C3= Collection Rate, Scale 3

CT= Collection Rate, Total

T = Temperature, Degrees C

A1 = Analog Channel 1

A2 = Analog Channel 2

A3 = Analog Channel 3

Unless a Balance is connected and properly configured, and the Filtrate Weight Alarm is enabled, the Q1 value will be replaced with CV.

The "Scale Initialization" and "Removing Tare Weight" screens will only occur in this case as well. When not using a balance it is important that you "Re-Cal" the system for increased accuracy.

"Display/Switch"

A1	0.0	A2	0.0
A3	0.0		

"STOP"

FF	0.0	P1	0.0
Q1	0.0	C1	0.0

PUMPING STOPPED
Press RUN to Finish

"EXIT"

CONSTANT PRESSURE
Exec Edit Prime

4.0 Programmable R-P: Programmed Variable Rate/Pressure Filtration

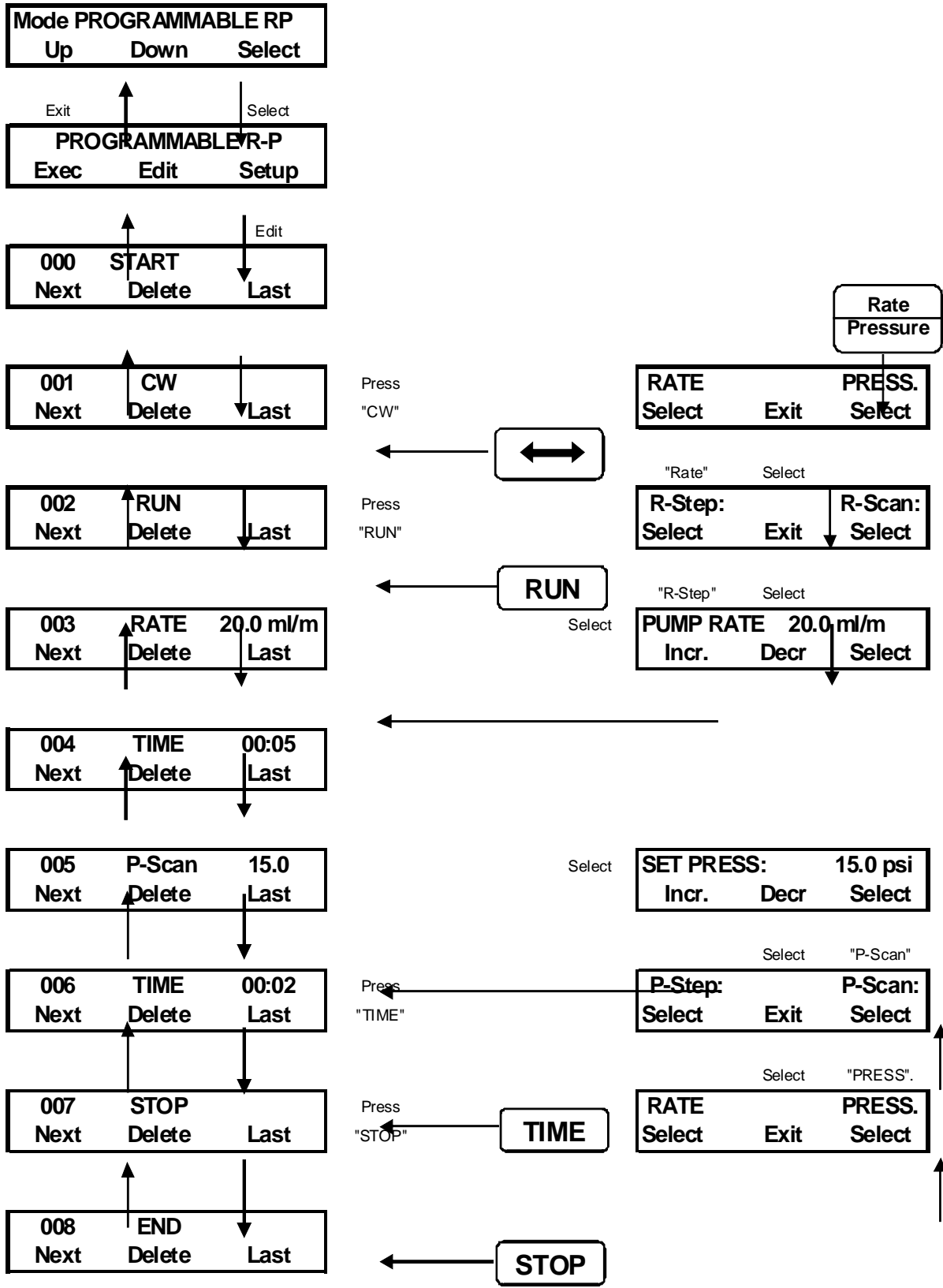

4.0 PROGRAMMABLE R-P: How to generate a PROGRAMMABLE R-P program.

SUMMARY: In PROGRAMMABLE R-P Mode you can generate a program that changes flow rates or controlled pressure rates in a stair-stepped (STEP) or ramped (SCAN) manner over time. If you wish, you can also control a pair of rotary selector valves, or repeat the program automatically.

When generating or editing a Programmable R-P program, all program statements that you want to see implemented during a specific timing block or interval **must precede the TIME statement for that block**. For example, on the next page, the program statement: 001 CW, 002 RUN, and 003 RATE are all implemented at the beginning of the first timing block defined by program statement 004 TIME: 00:05 (five minutes).

CW, Pump Direction: This program statement is implemented by pressing the front panel key with the double arrows. This key functions like a toggle switch and allows you to select either CW (clockwise) or CCW (counter-clockwise) pump direction.

RUN: This statement is implemented by pressing the front panel key labeled “RUN”, it instructs the FilterTec Plus to turn on the motor.

TIME, Timing Interval: Press TIME key, then select the desired timing interval in hours:minutes. All preceding program statements are implemented at the beginning of this TIME statement.

STOP: This statement is implemented by pressing the “STOP” key on the front panel. It instructs the FilterTec Plus to turn off the motor.

RATE, R-Step, R-Scan: Press “RATE” key then select RATE by pressing the “A” button. Select R-Step to set a flow rate to be maintained for a given Time period. Select R-Scan to set a flow rate to be scanned (ramped) up or down to over a given Time period. Please be sure that the selected flow rate does not exceed the capacity of the installed pump head /motor combination.

PRESSURE, P-Step, P-Scan: Press “RATE” key then select PRESSURE by pressing the “C” button. Select P-Step to set a pressure to be maintained for a given Time period. Select P-Scan to set a pressure to be scanned (ramped) up or down to over a given Time period. The controlled pressure is the one specified in SETUP, PUMP, Press. Sensor, Source.

Editing the program is accomplished using the “NEXT” “DELETE” and “LAST” keys. NEXT moves to the next line in the program, LAST moves to the previous line in the program, (i.e. backspace) and DELETE removes the line of the program currently displayed. To remove and replace a command, press “DELETE” and “LAST”, and then input the new command.

Optional Commands:

Vx, Wx, Valve Position: This program statement is implemented by pressing the star (*) key followed by selecting "Rotary Valve". Six rotary valve positions for valve "V", namely, V1 thru V6, as well as, six rotary positions for a second valve "W", W1 through W6, can be selected.

COUNT: Allows you to repeat the program automatically, and not generally used. Press star (*) key, then select "SAMPL COUNT", then select "1" if you want your program to run only once, select "2" if you want to run your program twice, etc. When used, it must appear at the end of the program.

Sample Programs:

A. Program to start at 20 ml/min, and every 10 min immediately change by 10 ml/min, for a total of one hour, then stop. (R-Step).

000	START		008	TIME 00:10
001	RUN		009	RATE 50 ml/m
002	CW		010	TIME 00:10
003	RATE 20 ml/m		011	RATE 60 ml/m
004	TIME 00:10		012	TIME 00:10
005	RATE 30 ml/m		013	RATE 70 ml/m
006	TIME 00:10		014	TIME 00:10
007	RATE 40		015	STOP

B. Program to start at 20 ml/min, and every 30 min scan up 20 ml/min over a 5 min period until a final rate of 80 ml/min has been run for 30 min. (R-Step & R-Scan)

000	START		009	R-SCAN 60 ml/m
001	RUN		010	TIME 00:05
002	CW		011	RATE 60 ml/m
003	RATE 20 ml/m		012	TIME 00:30
004	TIME 00:30		013	R-SCAN 80 ml/m
005	R-SCAN 40 ml/m		014	TIME 00:05
006	TIME 00:05		015	RATE 80 ml/m
007	RATE 40		016	TIME 00:30
008	TIME 00:30		017	STOP

4.1 PROGRAMMABLE R-P MODE: Setup Menu

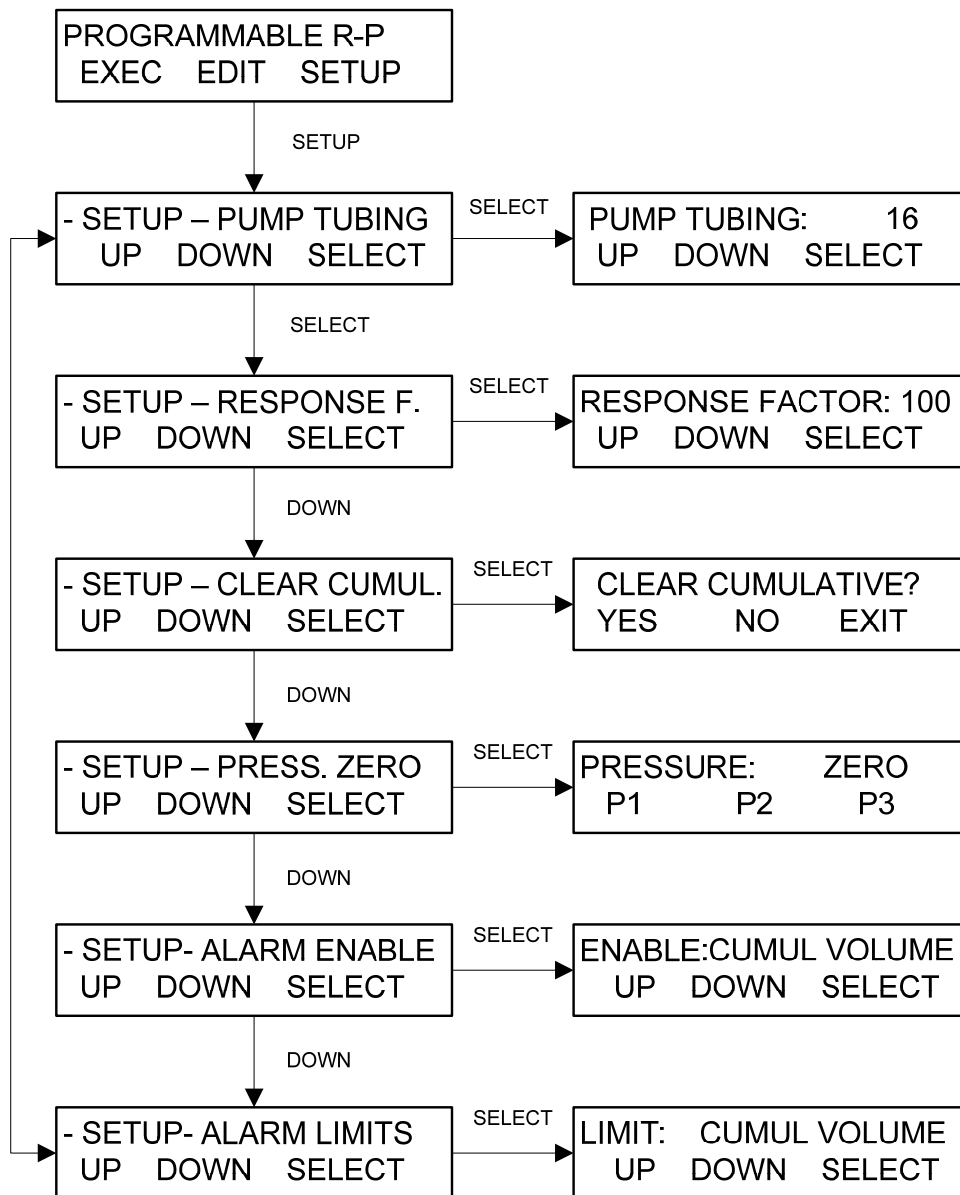

4.1 PROGRAMMABLE R-P: Setup

SUMMARY: The Setup menu is identical to the Edit menus in the other two modes except that the Pump Rate and Pump Pressure are input as part of the Step-by-Step instructions mentioned in the previous section.

Use “**Up**” and “**Down**” keys to make a selection, then press “**Select**” to implement that selection.

Pump Tubing: Select sizes #13, 14, 16, 25, 17, 15, 24 or #35, use “**Up**” and “**Down**” keys for choice of pump tubing size, then press “**Select**”. Based upon your selection, the FilterTec Plus will access factory installed calibration tables, which relate the system output in ml/min. to motor speed. The FilterTec Plus output can also be re-calibrated by the utilizing the front panel star (★) key. (See CONSTANT RATE Mode)

Clear Cumul: Resets (Clears) the following counters in the “Exec” front panel display: CV = Cumulative Volume; RT = Run Time; Q1 = Filtrate Weight.

Response F: Response Factor setting. The Pump Response Factor = 100 is the default value. Increasing the Pump Response Factor will increase the pumps responsiveness to pressure changes.

Pressure Zero: Allows you to zero the backpressure readings of all 3 pressure sensors. The FilterTec Plus pump must not be running when resetting pressure sensor output.

Alarm Enable: Allows you to select alarm options for five (5) different alarm conditions. There are 3 options available: 1. Disable the alarm (**Off**); 2. Enable an auditory alarm (**Alarm Only**); 3. Stop pump and provide an auditory alarm (**Pump Stop**) when user defined alarm limits are exceeded. The Hi-Pressure Alarm has a fourth option: **Pmaintain**, which allows you to switch from the rate control method to the pressure control method when running an R-Step or R-Scan step.

Alarm Limits: Allows you to assign alarm limits for several different alarm conditions:

Cumulative Volume in milliliters;

Hi-Temperature in °C;

Run Time in hours:minutes;

Lo-Pressure (monitor system leakage) in psi;

Hi-Pressure (Monitor filter plug-up);

Lo-Flow (high filter backpressure) in ml/min;

Filtrate Weight in grams. (This alarm must be enabled in order to obtain and display the Filtrate Weight (FQ).)

The Lo-Pressure, Hi-Pressure and Lo-Flow alarms are related to the pressure source chosen in **SETUP: Press. Sensor, Source**. The Alarm condition is triggered when alarm limit is exceeded.

Alarms are not mutually exclusive. You may select any combination of alarms.

4.2 PROGRAMMABLE R-P MODE: Alarm Limits Menu

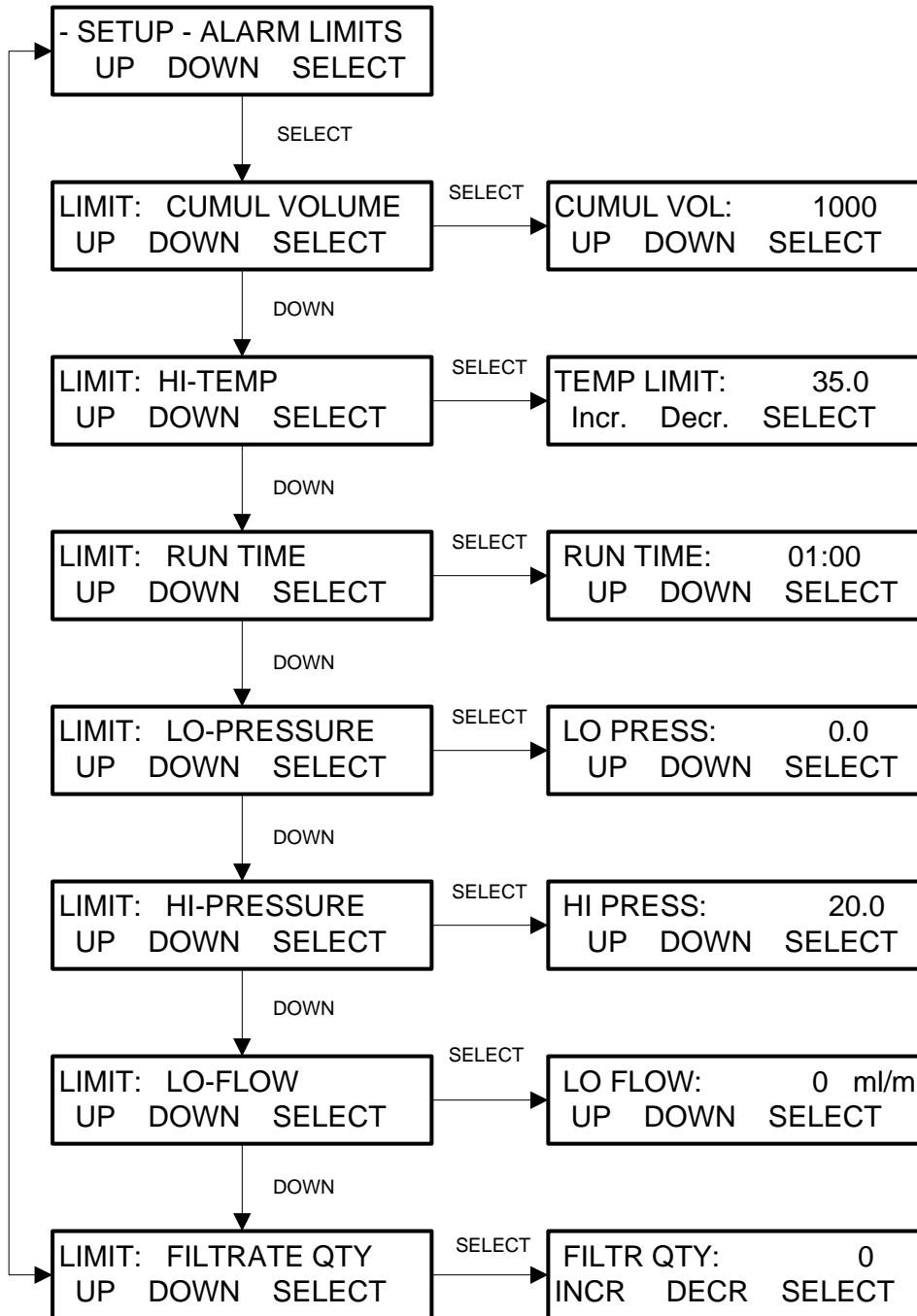

4.2 PROGRAMMABLE R-P: Alarm Limits

SUMMARY: This section describes assigning limiting values for several alarm conditions: **Cumulative Volume** in milliliters; **Hi-Temperature** in °C; **Lo-Pressure** (monitor system leakage) in psi; **Hi-Pressure** (Monitor filter plug-up) in psi; **Lo-Flow** (pump will stop when pump feed rate falls below this limit) in ml/min.; **Filtrate Quantity** in grams.

The alarm condition is triggered when the alarm limit is exceeded. Alarms are not mutually exclusive. You may select any combination of alarms.

For critical alarms you may want the FilterTec Plus pump to stop (**Pump Stop**). For less critical alarm conditions you may want to choose an auditory alarm (**Alarm Only**).



Please Note: The High and Lo-Pressure alarms are directly related to the Source chosen in SETUP: Press. Sensor, Source, i.e. P1, P2, etc.

Use “**Up**” and “**Down**” keys to make a selection, then press “**Select**” to implement that selection.

Cumulative Volume (CV): This alarm setting represents the total volume of process solution that is pumped through your filtration device when a balance is not in use. **When using a balance, set this limit in the Filtrate Weight Alarm!** For example: if you set the **Cumulative Volume Alarm** to 10,000ml or 10 liters, the FilterTec Plus will either alarm and / or stop the pump when 10 liters has been pumped through the filtration device.

Hi-Temp (HT): Used to monitor the temperature of the process solution, this will stop the pump at the set limit. Default = 35.0 °C

Lo-Pressure (LP): Typically set 3-5 psi units below the desired pressure setting in the step-by-step instructions. The Lo-Pressure Alarm is triggered when a sudden filter backpressure drop occurs after rising above this setting. Such a change in the filter backpressure usually indicates a system leak.

Hi-Pressure (HP): For most applications, this represents a critical alarm condition. If this is the case choose Pump Stop. Make sure you stay below the pressure limit specified by the filter manufacturer. I.e., if your filter specifies an upper pressure limit of 25 psi, you might set your **Hi-Pressure Alarm** to 20 psi. The FilterTec Plus will alarm and stop the pump when the filter backpressure exceeds 20 psi. If you have chosen **Pmaintain**, this is the value at which the system will switch from a Rate control method to the Pressure control method and maintain that pressure.

Lo-Flow (LC): For constant pressure filtration, this represents a critical alarm condition and should be set to **Pump Stop** in Lo-Flow Alarm Enable. In this operational mode, the FilterTec Plus will detect any filter backpressure increases in the source pressure sensor (due to slow filter plug-up) and automatically decrease the rate to maintain the desired pressure setting in the step-by-step instructions. The Lo-Flow value (ml/min) represents lowest pump rate before the pump shuts down.

Filtrate Qty. (FQ): The FilterTec Plus comes with a top-loading balance. Enter the filtrate quantity (grams) that you want to collect, and the FilterTec Plus will either alarm or stop the pump when the desired filtrate / permeate weight has been collected. Set this value to zero if you do not wish it to trigger during normal use.



Note: This alarm must be enabled in at least “alarm only” mode in order for Q1 (Filtrate Quantity) to be obtained or displayed.

5.0 SETUP

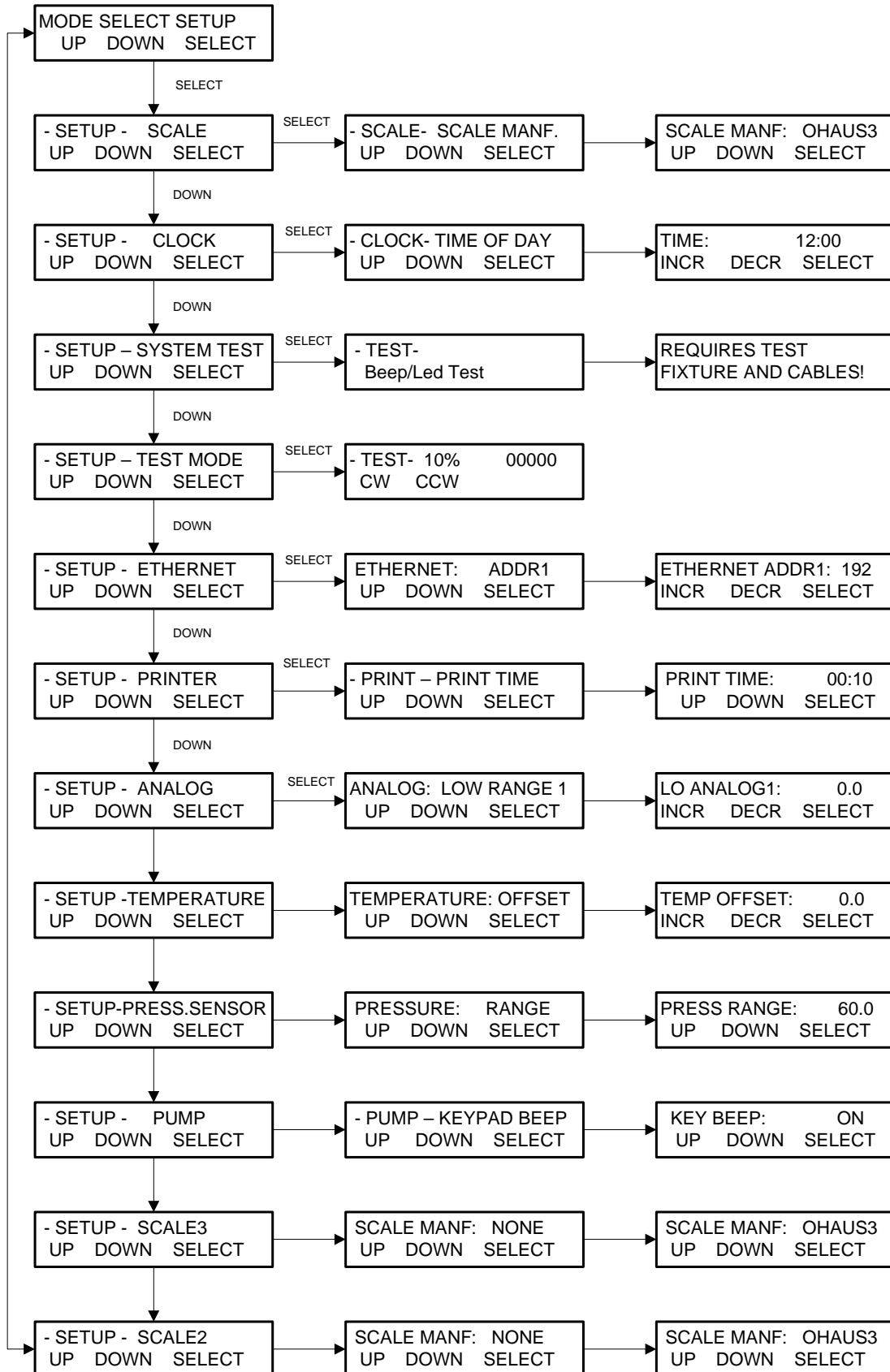

5.0 Setup

Summary: The Setup Menu consists of the following items; the following sections provide further explanation:

Scale: The following electronic scale is recommended for the FilterTec Plus and will ship with most systems: **Ohaus Adventurer Pro**. Proper communications are set by selecting Ohaus 3 as the Scale Manuf. Other scales, Mettler, Ohaus or Sartorius may be used. Submenu allows setting of Scale Manuf., Units, Alarm, and Tare. Default = "Ohaus3".

Clock: Set the time of day (military), **day**, **month**, and **year**. **Print Enable** allows choice of Time of Day, or Relative (Run) Time for printout and display. In most cases the clock will be set at the factory for the destination time zone. Default = Time of Day.

System Test: Allows testing of the I/O's of the FilterTec Plus, requires purchase of IQ/OQ Document. Use Test Mode if needed for trouble shooting.

Test Mode: Allows independent testing of the FilterTec Plus I/O's. Motor, Keypad, Scale, Pressure, Temperature, Valves, Analog, TTL switches.

Ethernet: Allows setting of the IP Address, Subnet Mask and Gateway values for Modbus TCP/IP communication via the Ethernet Port.

Printer: Select communications parameters for SciLog printer (P/N 080-095) or PC. Default settings are **Print Time** (Default = 10 sec.), **Type** (Seiko), **Baud Rate** (9600), **Stop Bits** (2), **Parity** (None), **Word Length** (8), **Print Delay** (0 sec).

Analog: Allows setting of Hi and Lo Range, as well as Hi and Lo Limits, Alarms and Zeroing of all three available 4-20 ma analog inputs.

Temperature: Select an Offset for the SciTemp Temperature sensor if needed.

Press. Sensor: Allows user to **Zero** all three SciPres pressure sensors. (**Span** is used for factory calibration.) **Source** is used to select the desired sensor for related alarms and control in all modes. **Units:** Choose from Psi (default), Bar, or Kpa. **Range:** Default is 60, can be set lower, will require re-calibration of the input. Contact SciLog Customer Service for assistance..

Pump: Select the following user preferences: **Keypad Beep:** (On/Off), **Switch Configuration:** (Level / Pulse), **Switch Polarity:** (Normal/Inverted), **TTL1:On-Off:** (Yes/No), Set Yes if controlling another pump as a slave, set NO if controlling Rotary Selector Valve "W". **Motor Start:** (Hard / Soft-Ramp), **Motor RPM:** (3400, 600, 160, 8), **Pump Head:** (Peristaltic/RH1/RH0/RH00), **Pump Tubing:** (13/14/16/25/17/18/15/24/35), **Power Up:** (Mode/Menu/Run), **External Run-Stop:** (Pulse/Level), **ASCII Feedback** (On / Off), **Factory Reset:** (Resets all variable parameters to their original factory defaults).

Scale2 and Scale3: The following electronic scale is recommended for the FilterTec Plus and will ship with most systems: **Ohaus Adventurer Pro**. Proper communications are set by selecting Ohaus 3 as the Scale Manuf. Other scales, Mettler, Ohaus or Sartorius may be used. Default = Ohaus3 for both scales. Set to "None" if using fewer than three scales, or a "Scale Error" will occur at initialization.

5.1 Setup: Scale

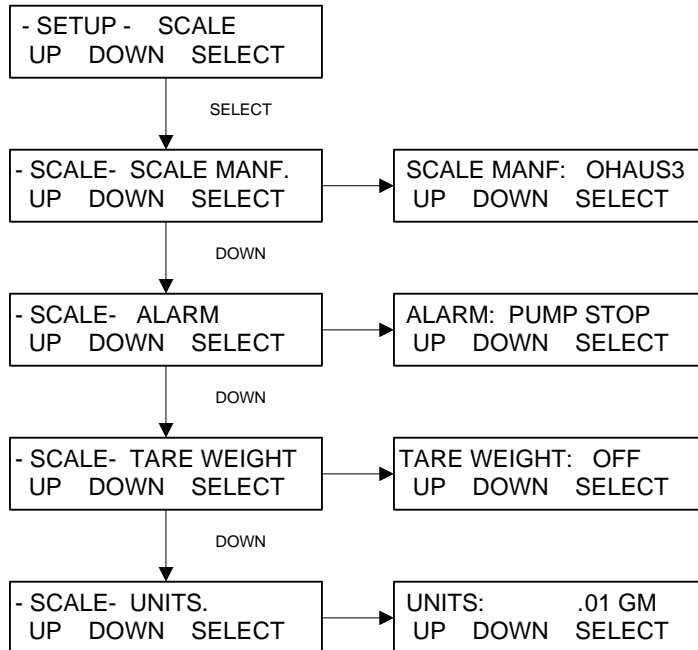

- **Scale Manuf:** Select the appropriate value for the scale in use. Options: Ohaus, Ohaus2, Ohaus3, Mettler, Metler2, Sartor, Sartor2. Default = Ohaus3. Proper configuration of the scales parameters is required, as well as correct interface cable.
 - Ohaus3: Adventurer Pro.
 - Ohaus2: Adventurer, Explorer, Explorer Pro.
 - Mettler: Viper, Series 4, IND560.
 - Metler2: Speedweigh, Panther.
 - Sartor2: Current default Sartorius setting, all series.
- **Alarm:** Triggered if communication with the scale is lost. Options: Pump Stop, Alarm Only or Off. Default = Pump Stop.
- **Tare Weight:** Determines if the system tares the scale upon pressing Execute and Run in the main operational modes. This is counterintuitive. Options: On, Off. Default = OFF, which causes the system to tare the scale. ON will cause the tare to not occur.
- **Units:** Select from: .001 gm, .01 gm, 0.1 gm, Kg, T, Lbs, OzT, Oz, C, Dwt. Default = .01 gm.

An Ohaus Adventurer Pro AV8101 scale is normally sent with the system when purchased. If a different scale is required, please contact SciLog for configuration information.

5.11 Ohaus Adventurer Pro Balance Parameters:

Press and hold the Menu button until MENU appears on the display. Release this button, and now use the Yes, No, and Back buttons to navigate the Sub-menus. Press the Tare button to exit the menu.

Please set the following Menu Items, all others are left at their factory defaults:

ReadOut

AutoZero	Off
Filter	Low

Print-1

Output

Whenstable	Off
AutoPrint	Off

Content

Num Only	Off
Header	Off
Gross	Off
Net	Off
Tare	Off
Reference	Off
Result	<u>On</u>
GLP	Off

Layout

Line Format	Multi
-------------	-------

RS232-1

Baud	9600
Parity	7 No Parity
Handshake	Off

In the Setup Mode, Scale Manuf., select "OHAUS3". By making this selection, the FilterTec Plus will implement the correct parameters for communicating with the Adventurer Pro Series balance. You will also need SciLog P/N 080-067PGS, Balance Cable. (Note: The 080-066 SciLog Ohaus Balance cable will not work with this balance series.)



NOTE: The Scale Communication settings for the updated (have the blue buttons with white text) FilterTec Plus and FilterTec Plus Plus have returned to match the settings used by all other SciLog bench top systems. They no longer require continuous output.

5.2 Setup: Clock

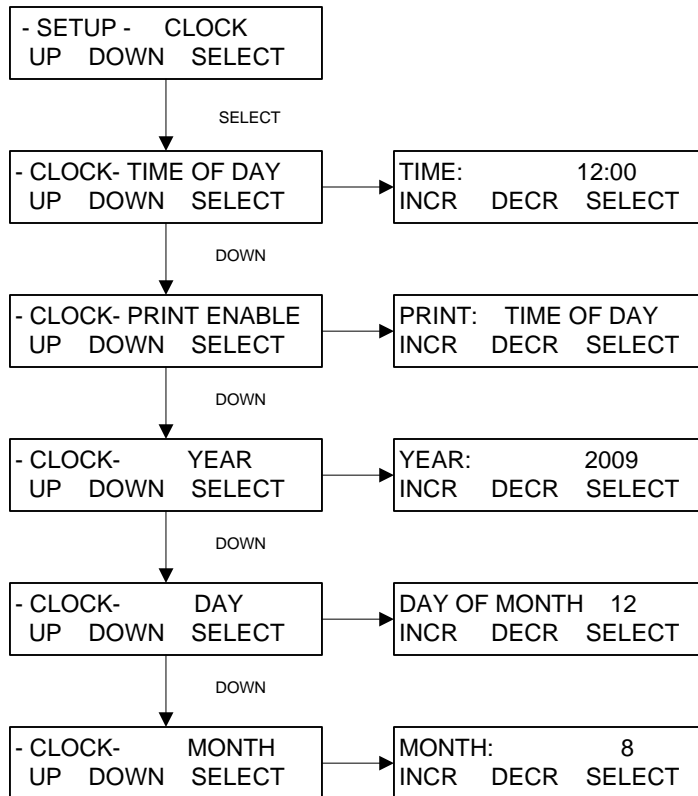

Clock is used to set the Date and Time in the FilterTec Plus real time clock, and control the displayed and output time format.

- **Time of Day:** Press Select and use the Incr. and Decr. buttons to set the current time in 24 hour format. This should be preset by the factory prior to shipping.
- **Print Enable:** Controls displayed and output time. Choose between Time of Day and Relative Time. Time of Day yields current time, and Relative Time starts at 00:00:00 at the beginning of a processing run. Default = Time of Day.
- **Year:** Press Select and use Incr. and Decr. to set the current year.
- **Day of Month:** Press Select and use Incr. and Decr. to set the current day of the month.
- **Month:** Press Select and use Incr. and Decr. to set the current month.

5.3 Setup: Test Mode:

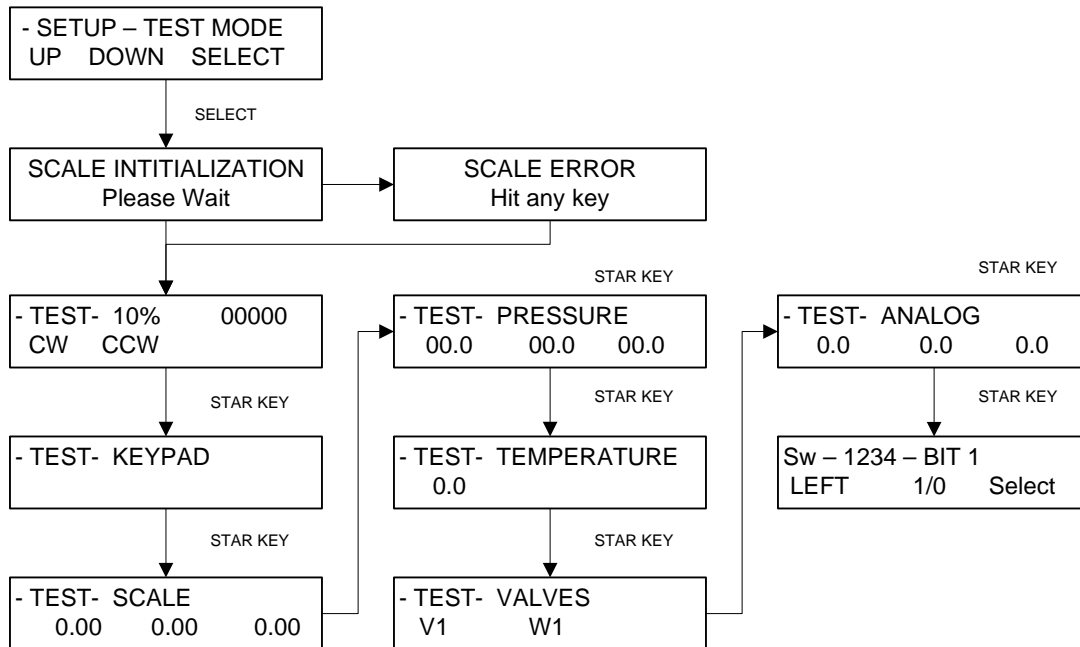

Test Mode provides the ability to test the inputs and outputs (I/O's) of the FilterTec Plus outside of the normal operational modes. Upon pressing Select, the FilterTec Plus will attempt Scale Initialization. If it passes, the next Test appears. If it fails, press any key and the next Test appears. Use the Star (*) button to move between tests.

- **Motor:** This tests the motor. Use the Rate/Pressure button to change the motor speed. Use the Run / Stop buttons, and the CW / CCW keys to exercise the motor. The encoder pulses/second is displayed.
- **Keypad:** This tests the keypad. Press the buttons in any order, and an appropriate number is displayed. Left to right, top to bottom, they are numbered 1 through 0, the Star key passes if it moves to the next test.
- **Scale:** If a scale is connected and is communicating properly, the value here will match that of the scale.
- **Pressure:** If SciPres Disposable Pressure Sensors are connected, they will display the measured pressure, P1, P2, P3. By pressing the A, B, or C keys, the sensors may be zeroed. If there is no sensor connected, --.- will be displayed.
- **Temperature:** If a SciTemp Disposable Pressure Sensor is connected, the measured temperature in °C will be displayed. If no sensor is connected, 0.0 is displayed.
- **Valves:** If Valve V or W is connected, press the A or B button to test them.
- **Analog:** Displays the analog value for Channels 1, 2 and 3 based upon input and Hi/Lo range settings.
- **TTL Switches:** By using Left and 1/0 to change the BIT setting, the TTL outputs may be tested. You must have a DMM connected to measure the voltage, it will be 0.0 if Switch is set to 0, and 5.0 Vdc if set to 1. (display is 1234 if all are high, 0000 if all are low)

5.4 Setup: Ethernet

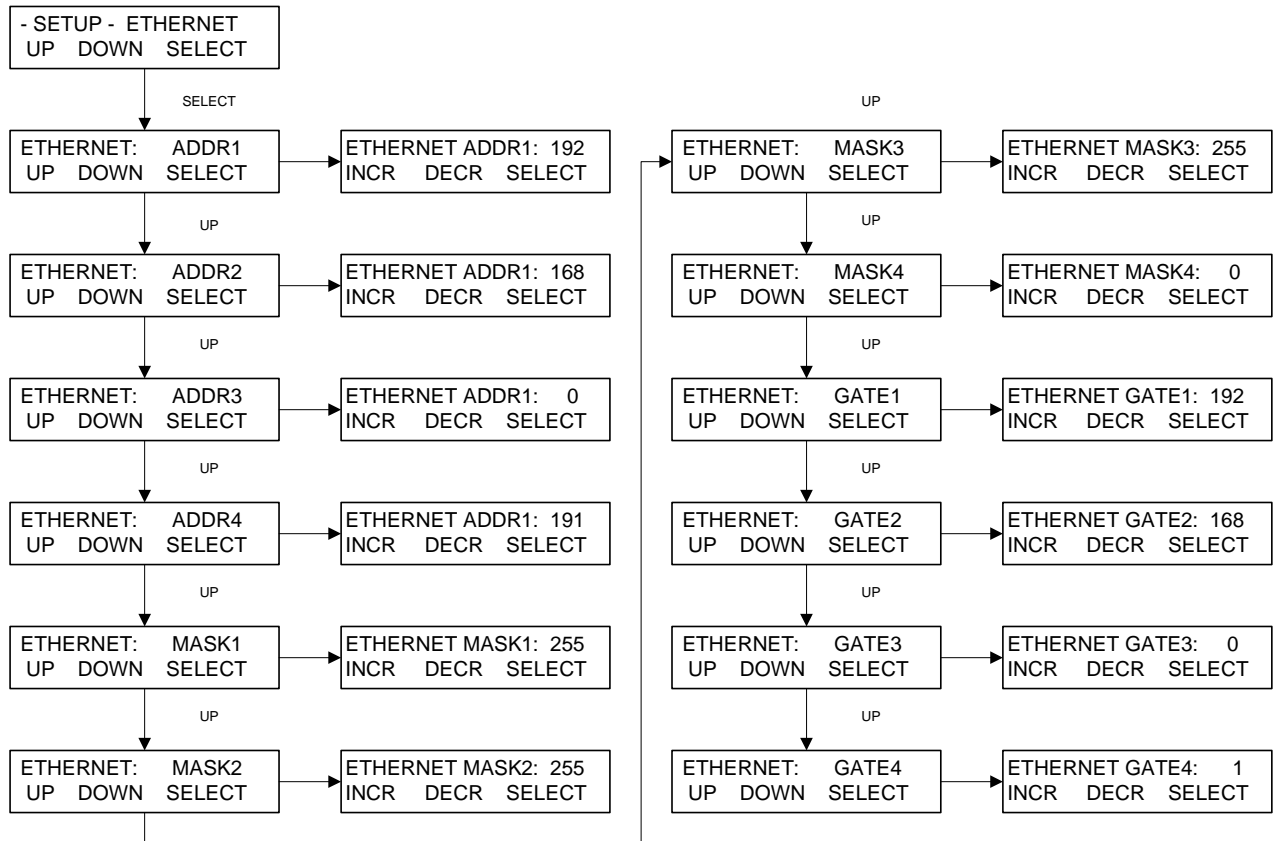

Ethernet allows setting of the IP Address, Subnet Mask and Gateway for the FilterTec Plus. This allows communicating with the FilterTec Plus via Modbus TCP/IP when it becomes available. Initially, if set properly for the company network, the user can ping the unit from a command prompt. Consult the company Network Administrator for the proper settings. A crossover cable can be used if connected directly to a PC, otherwise use a standard network patch cable and a hub or switch.

- **IP Address:** The default IP Address for the FilterTec Plus is 192.168.0.191. Use ADDR1 through ADDR4 to modify this address.
- **Subnet Mask:** The default Subnet Mask is 255.255.255.0. Use MASK1 through Mask4 to modify this address.
- **Gateway:** The default Gateway is 192.168.0.1. Use GATE1 through GATE4 to modify this address.

5.5 Setup: Printer

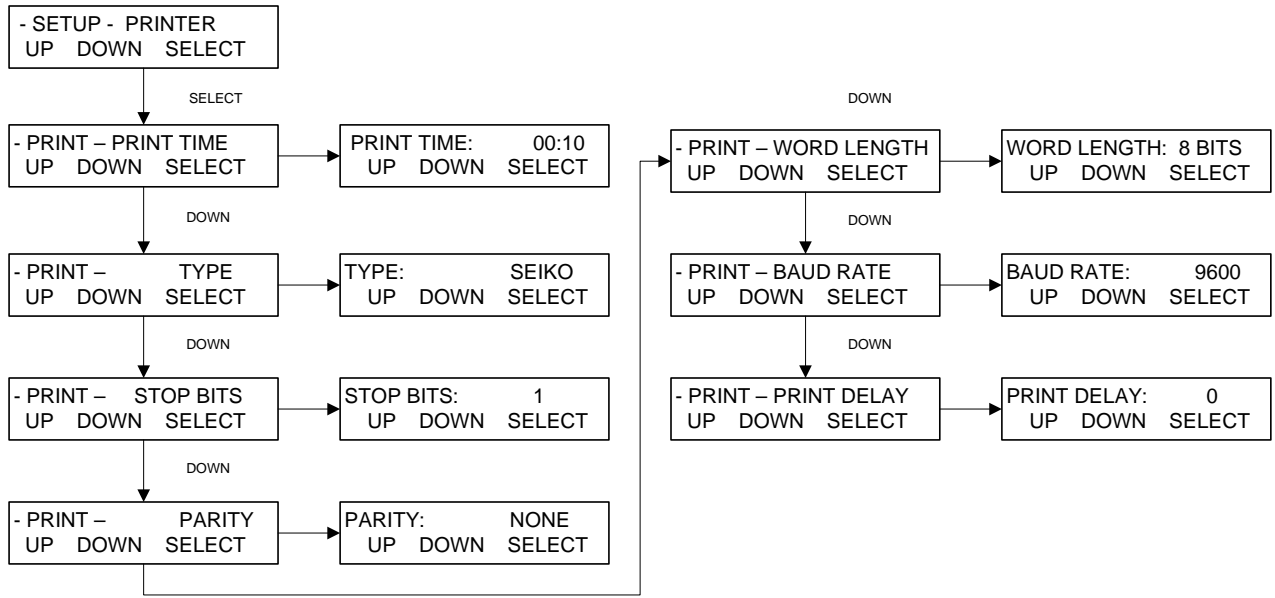

Printer allows the setting of RS-232 communication parameters needed for connection to a SciLog serial printer or to a PC for data collection.

- **Print Time:** Controls how fast the FilterTec Plus sends data points in Minutes: Seconds. Max is 30:00 minutes; Min is 00:05 seconds. Default = 00:10 seconds.
- **Type:** Allows use of two styles of small serial printers, Seiko, a thermal unit, and Starr, a dot matrix. For all other printers, and PC communication, Seiko setting is used and is the default.
- **Stop Bits:** Select 1 or 2. Default = 1.
- **Parity:** Select Even, Odd or None. Default = None.
- **Word Length:** Select 7 or 8 Bits. Default = 8 Bits.
- **Baud Rate:** Select 300, 600, 1200, 2400, 4800, 9600, or 38.4. Default = 9600
- **Print Delay:** Used to slow down the output for printers with small buffers. Select 0 – 5 seconds. Default = 0 seconds.

5.6 Setup: Analog

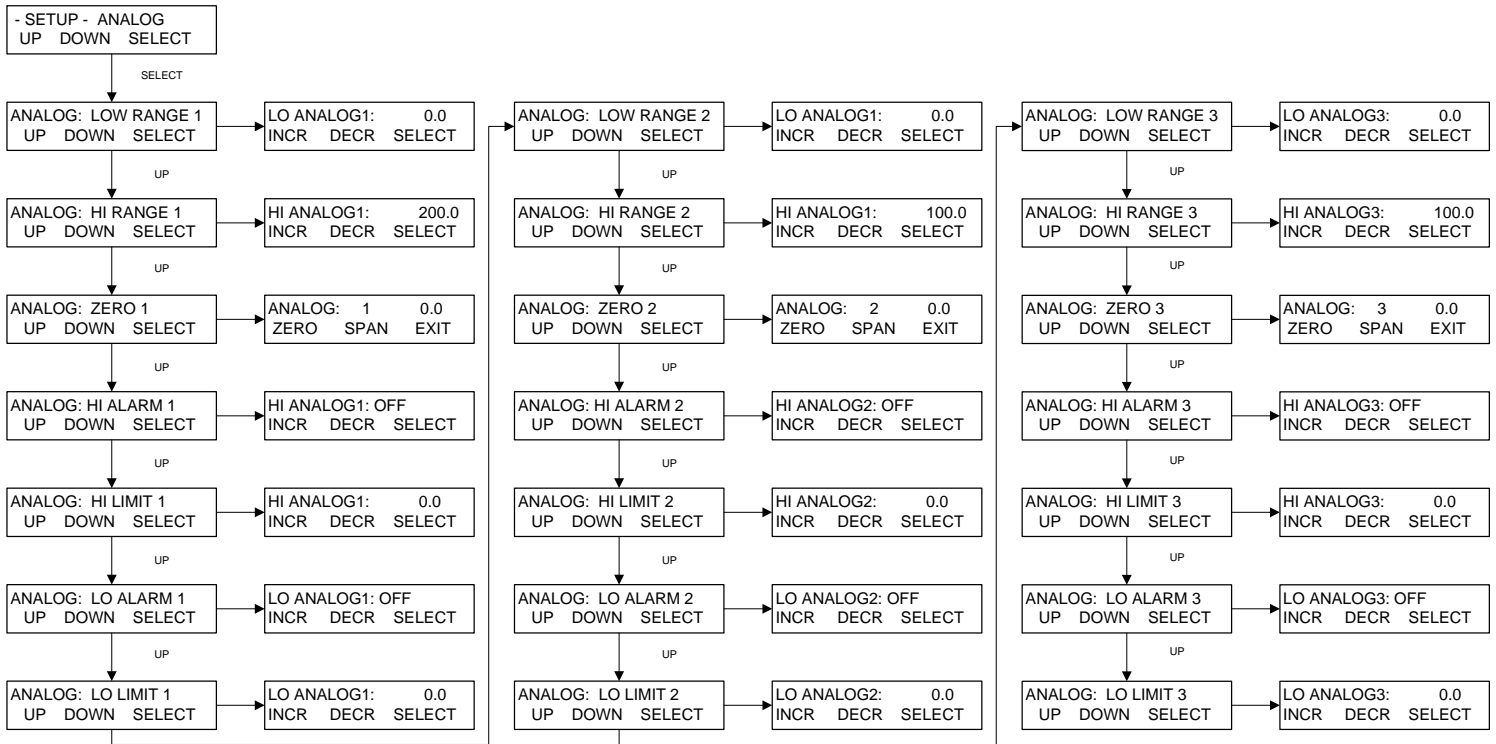

Analog provides for configuration of the three available 4-20 mA Analog inputs. The Hi/Lo Range values can be set, the signal can be calibrated via a Zero/Span function, and Hi/Lo Alarms and Limits can be set for any or all three of the inputs.

- **Lo Range 1:** Set the value for the 4 mA input on Channel 1. Default = 0.0
- **Hi Range 1:** Set the value for the 20 mA input on Channel 1. Default = 200.0
- **Zero 1:** Provides for calibration of the Analog Channel 1 input. Provide a 4 mA signal and press “Zero”. Provide a 20 mA signal and press “Span”. Press Exit to finish. The device being interfaced or a source traceable to NIST should be used for this procedure.
- **Hi Alarm 1:** Choose the enable setting for a Hi Alarm on Channel 1. Select between Off, Alarm Only and Pump Stop. Default = OFF
- **Hi Limit 1:** Set the Limit for Hi Alarm 1. The alarm is triggered when the value is exceeded. Default = 0.0
- **Lo Alarm 1:** Choose the enable setting for a Lo Alarm on Channel 1. Select between Off, Alarm Only and Pump Stop. Default = OFF
- **Lo Limit 1:** Set the Limit for Lo Alarm 1. The alarm is triggered when the value drops below the limit after first exceeding it. Default = 0.0



Note: Analog input channels 2 and 3 are the same, except the default for the Hi Range is 100.0. Maximum range value for any channel is 9999.9.

5.7 Setup: Pressure Sensor

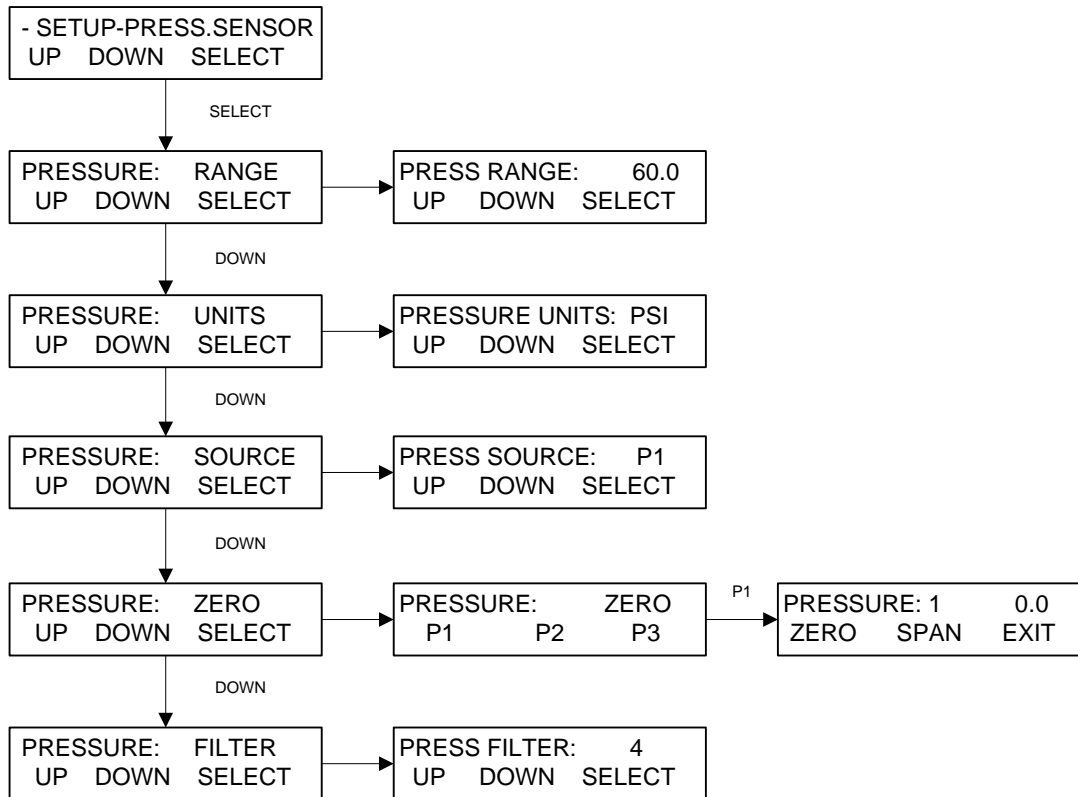

Pressure Sensor is used to configure settings related to the SciPres Disposable Pressure Sensors. The following can be configured; Range, Units, Source (control and alarms), Filter (signal noise) and Zero/Span.

- **Range:** Set the overall pressure range, the Default is 60.0 psi, and is the maximum. Changing this setting requires re-calibration of the sensor signals.
- **Units:** Select between Psi, Bar, and KPA. Default = Psi.
- **Source:** Controls the source pressure sensor for control in Constant Pressure Mode, and for all pressure alarms. Select between P1, P2 or P3. Default = P1
- **Zero:** Used to “Zero” the sensors to establish the zero offset cause by the circuitry and any inherent hydraulic pressure in your tubing beyond the pump head. Connect the sensor, and remove any pressure from the system. Select the sensor, P1, P2 or P3 and press “Zero”. You are prompted to confirm the action. “Span” should not be used on a routine basis, as it sets the max input value. NOTE: Do not Zero P1, P2 or P3 unless a sensor is connected. The display should read “--.-“ with no sensor connected. If it reads 0.0 in this state, connect the sensor and re-zero it.
- **Filter:** This feature filters out the pulsations in the pressure signal due to the peristaltic nature of the pump head. This provides better control and easier to read values, as well as improved graphed data. Select from 1 to 7, 1 = no signal filter, 7 = maximum filter. Default = 4.

5.7 Setup: Pressure Sensor, Calibration

The FilterTec Plus has built in calibration curves for the SciPres disposable pressure sensors that are inherently very accurate for the installed default range of 0 – 60 psi, and there should be no need for you to change it. If your metrology department insists that they calibrate them periodically, the procedure follows.

To calibrate the FilterTec Plus / SciPres Disposable Sensors:

1. Obtain a NIST traceable regulated source of compressed gas (i.e. air, nitrogen) and pressure gauge.
2. Go to Mode Select; Setup; Pressure Sensor, then to Pressure: Range, and note the range specified, change if desired. (Default is 60 psi.)
3. Press Exit and scroll to Pressure: Zero.
4. Choose P1.
5. With no pressure on the sensor, press Zero (“A” button).
6. Connect regulated pressure source to P1, and carefully increase to match range noted in step 2.



Note: Pressurizing the SciPres Sensors beyond 60 psi can damage the sensor.

7. Press Span (“B” button).
8. Turn off pressure source, Press exit.
9. Repeat steps 5 – 8, choosing P2 and then P3.
10. You have now recalibrated (spanned) all 3 SciPres sensors. It is still advisable to zero each sensor again with no pressure in the system, prior to running your tests via the Edit: Press. Sensor menu in the operating mode of choice.

5.8 Setup: Pump

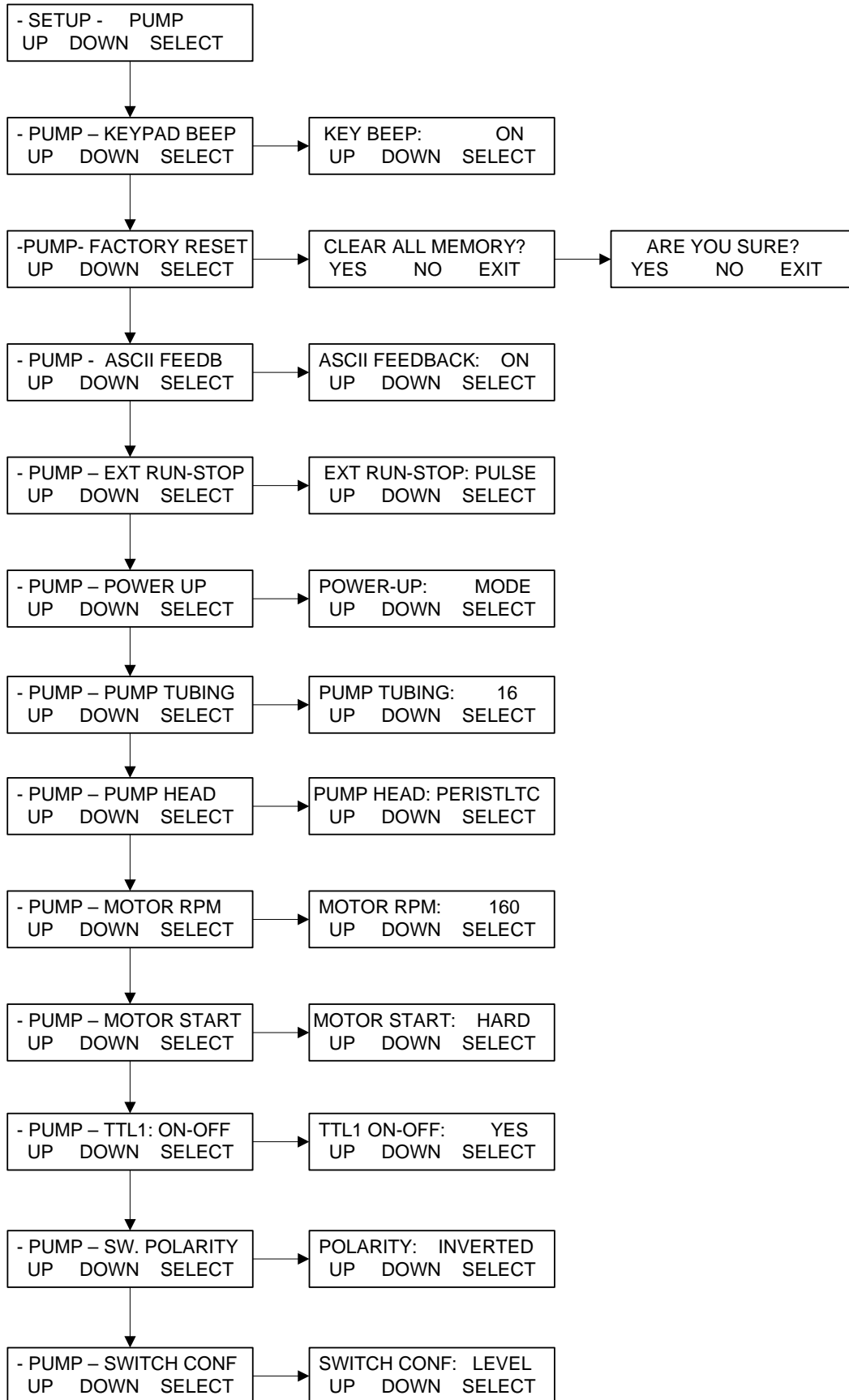

5.8 Setup: Pump, continued:

Setup: Pump provides configuration of global settings related to the pump. Generally, the default values here do not need to be changed. Any changes required for a particular system will be made at the factory, and would only need to be modified if a “Factory Reset” is performed.

- **Keypad Beep:** Determines if the buttons “beep” when pressed. Default = ON.
- **Factory Reset:** Resets the system to the factory default settings for all menus. Requires pressing “YES” to both the “Clear All Memory?” and “Are You Sure?” prompts.
- **ASCII Feedback:** Controls responses sent to a PC upon receipt of a remote command. Default = ON.
- **External Run-Stop:** Controls action of the Footswitch connection, which is part of the External I/O DB37 connector (pins 19 and 37). Choose Pulse for footswitch type control where the contacts are closed and then opened. Choose Level for contact closure control where closed = Run and open = Stop. Run key is disabled when this is set to Level except in Manual Mode. Default = Pulse.
- **Power-Up:** Controls the action of the system upon power-up. Choose from Menu, Mode, or Run. Menu = the system returns to the top of the Menu. Mode = the system returns to the last Mode it was in. Run = the system returns to the last Mode it was in and starts the process.
- **Pump Tubing:** If Pump Head is set to Peristaltic, all nine standard tubing sizes can be chosen. Used with Motor RPM setting to determine proper calibration curve. Default = 16.
- **Pump Head:** Choose between Peristaltic, RH1, RH0 and RH00. Also used to access the proper calibration curve. Default = Peristaltic.
- **Motor RPM:** Choose between 8, 160 and 600 rpm, matching the motor installed in the system. This will be set at the factory. It will need to be reset after a Factory Reset if other than the default. Default = 160.
- **Motor Start:** Controls how fast the motor starts. Hard is fast, Soft is slow. Default = Hard.
- **TTL 1 On-Off:** Controls action of TTL Switch 1, used for Master/Slave control of another system or device with TTL input control. Set to Yes, TTL 1 changes states from High to Low when the system is told to run the motor. Set to No, it does not. Default = Yes.
- **Switch Polarity:** Controls the polarity of the TTL switches. Inverted = High when not activated, Low when activated. Normal = Low when not activated, High when activated. Default = Inverted to allow for proper Master/Slave control.
- **Switch Configuration:** Sets the action of the TTL switches. Choose between Level and Pulse. Default = Pulse. Set to Level to allow for proper Master/Slave control.

6.0 Manual:

Summary: In the Manual Mode the FilterTec Plus pump can be manually operated. The pump speed can be set by pressing the “Rate” key. The pump will also display the pressure indicated on SciPres sensor P1.



Note: The **CONSTANT RATE** and **CONSTANT PRESSURE** parameters, including the alarms, cannot be accessed in the **Manual Mode**.

When in **CONSTANT RATE** or **CONSTANT PRESSURE** operational modes, the pump speed and/or pressure can be adjusted in terms of % motor speed while the pump is running. Just press the “RATE” key, make the appropriate adjustment, and press “SELECT”.

7.0 Data Acquisition:

Summary: SciLog has available a software package called SciDoc that includes data collection software and a Custom Excel spreadsheet that is automatically populated when any of the modes are executed except Manual. It also has charts that are automatically populated as the data is generated. See Section 7.1 below.

Either the Printer Port or USB Port may be used for data collection. The instructions for installing the USB driver appear at the beginning of this manual. The FilterTec Plus Printer Port is required for use with a SciLog serial printer, and both Thermal and Dot Matrix are available. By using both ports, the data can be simultaneously captured on a PC and a Printer.

When a PC is connected, all data generated in RATE, PRESSURE, and STEP-SCAN modes can be sent to the PC for archiving. Please use the SciLog SciDoc Data Collection Software described below. Alternatively, a PC running “HyperTerminal”, a program that comes with Windows, may be used to capture the data. The HyperTerminal settings are provided for you in section 7.2 entitled “PC HyperTerminal Settings.” When interfacing with a PC you will need a separate RS-232 cable (P/N: 080-073) or USB cable (P/N: 090-158)..

Note: For a successful hook-up with your PC, the FilterTec Plus and the PC must use the same communications protocol. Make sure that the communication parameters in Setup: Printer are the same as those listed in for HyperTerminal below or the default values.

The FilterTec Plus is also equipped with a USB port that can be connected to your PC. You will find the driver for this connection on the CD this manual came on. You will need to look in Device Manager on your PC to determine the Com Port number assigned to the FilterTec Plus.

The FilterTec Plus is also equipped with an Ethernet Port. Settings for the Ethernet connection are described in section 5.4. This is for communication via Modbus TCP/IP, and when the register list is available, it will be added to the manual as an appendix.

7.1 FilterTec Plus SciDoc Data Collection Software:

SciDoc is a software package that captures the data output of the FilterTec Plus and places it in an Excel spreadsheet. This spreadsheet also performs some basic calculations and populates several graphs to aid you in the analysis of your process. It consists of a copy of WinWedge32 from TalTech Inc. and a custom spreadsheet with built in macros. It requires the use of a SciLog RS-232 cable, (P/N: 080-073) or USB cable, (P/N: 090-158) to connect your FilterTec Plus to an available Com Port on your PC.

Minimum system requirements for are Windows 98 and Excel 2000. WinWedge32 v3.4 is included in the package and is Vista compatible. Installation instructions are included with the package.

Once installed, click on the shortcut for the spreadsheet, and the following dialog box is presented:

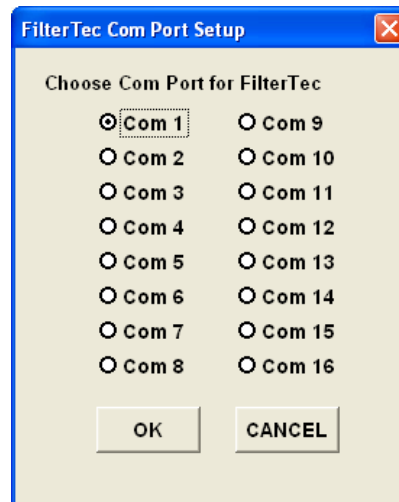

If you do not get this screen, you will need to change the Macro Security settings in Excel. If it does not prompt to enable macros or does not prompt for the COM port, the security level is too high.

1. If using a version of Office older than 2007, from the Excel menu bar, click on Tools, Macros, and Security. Set it to Medium, close the spreadsheet and re-launch it.
2. If using Office 2007, from the Excel window, click on the Office logo in the upper left corner. Then click on Excel Options in the lower left of this window. Highlight the Trust Center, and click on Trust Center Settings in the lower left.
 - a. In this window you have two options:
 - i. Click on Trusted Locations, then Add new location, browsing to the Winwedge folder where the spreadsheet is located and making it a trusted location.
 - ii. Click on Macro Settings, and choose Enable all macros.

Choose the Com Port the FilterTec Plus is connected to. Click on the OK button and WinWedge32 will start, showing itself as an icon in your system tray.



If you chose cancel on the Setup dialog box, WinWedge32 won't be in the system tray, and you will need to click on the "Com Port Setup" button to complete this task in order for data collection to be possible. Once this is complete, you will have the next dialog box:

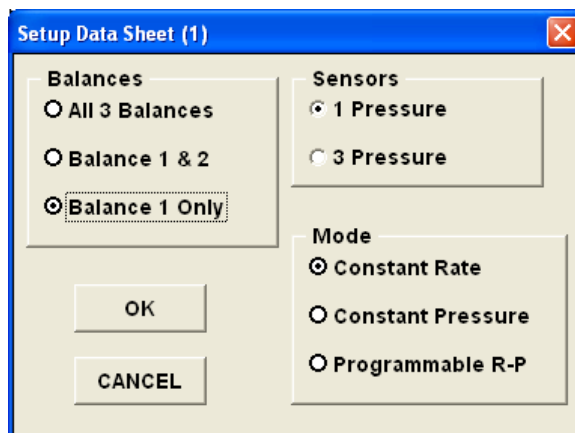

Here the data sheet is setup for the mode being used and the number of pressure sensors in use.

As this spreadsheet is also used for the FilterTec, options for one, two or three balances exist. Setting it for less than three will not affect the data received; there may be columns of data that are hidden.

Most common will be Constant Rate Mode and three Sensors. Choose the mode and either one or three sensors and click on OK. These choices may be changed between runs if the need arises by pressing the “Data Sheet Setup” button on the spreadsheet.

After pressing the ok button, the next dialog appears:

Operator	
Date	
Time	
Product Batch Number	
Product Description	
Conditions	
Membrane Manufacturer	
Membrane Type	
Membrane Lot Number	
Membrane Serial Number	
Membrane Pore Size	
Membrane Surface Area, Square Meters	0.000962

Enter the operator’s information and that of the filter and sample being run.

The Membrane area in square meters is a mandantory field, and must be filled in for Flux calculations to function properly.

A default value of .000962 sq meters is entered for those using 47mm diameter filters. These fields may be updated for later runs by pressing the “Operator Info” button on the spreadsheet.

After pressing OK, the empty datasheet appears:

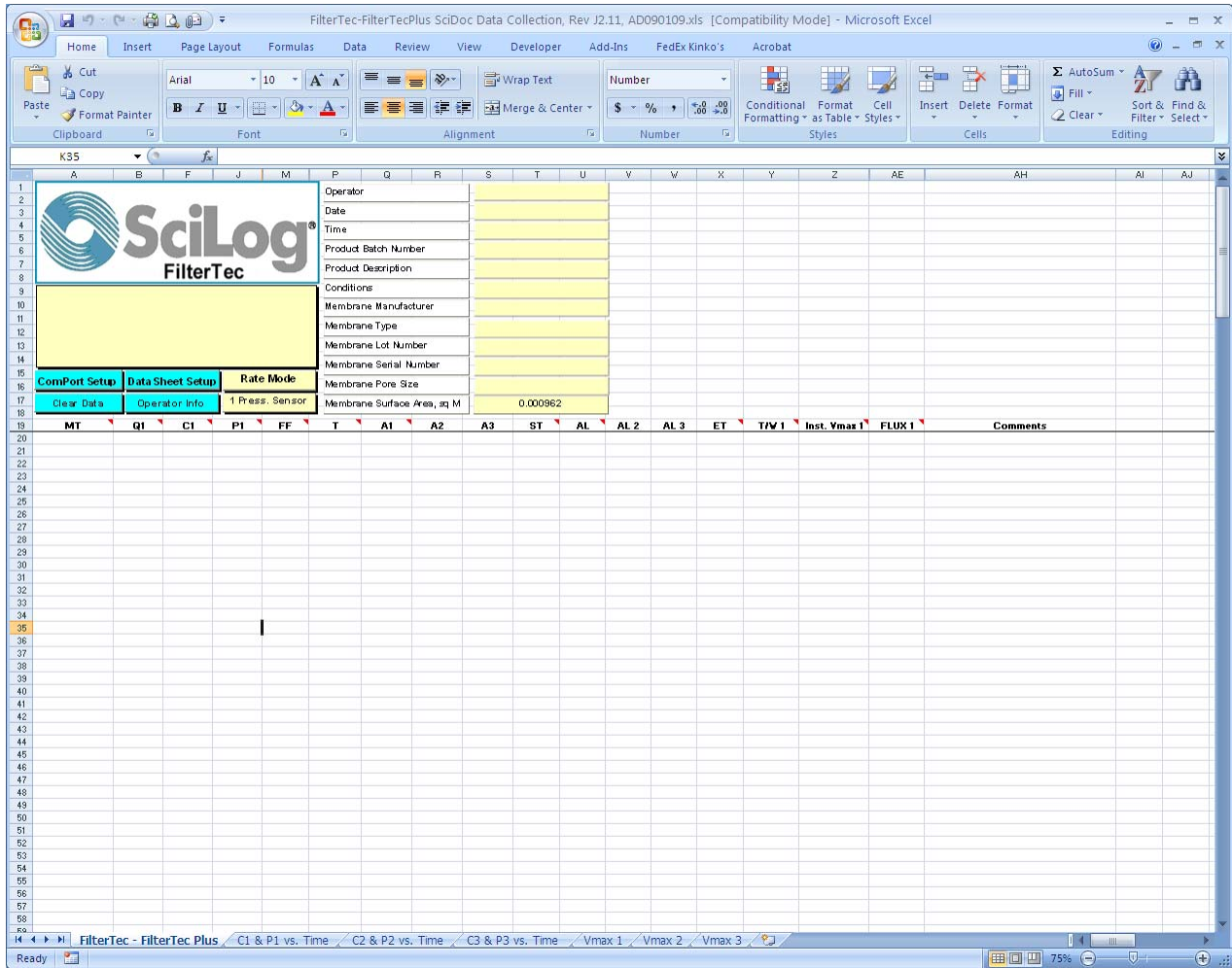

When ready, press EXEC on the FilterTec Plus, and then RUN after the balance has initialized. The data generated will automatically be placed in the cells of the spreadsheet, and the charts populated with the same data. The text box in the upper left of the spreadsheet contains the header information that is generated by the FilterTec Plus. This will list the Operational Mode, the date and time, all operating parameters, alarm settings and alarm limits.

The following charts are included for use, and they may be viewed by clicking on the appropriate tab at the bottom of the worksheet:

- Filtrate Flow Rate (FF) and Pressure vs. Time
- Filtrate Flow Rate (FF) and Filter Quantity(FQ) vs. Time
- Vmax, which is T/W (seconds/gram) vs. Time (elapsed time, seconds)

Other charts may be created, or the existing charts may be modified if needed.



A couple items of Note: The columns that are visible on the spreadsheet will change based on the mode, the number of sensors chosen, and the number of balances chosen.

- Choosing three sensors will yield columns for P2, and P3.
- Choosing Programmable RP Mode will yield columns for the position of Valves V and W.
- Choosing multiple balances will yield columns for Q2, Q3, QT, C2, C3 and CT, which relate to the Quantities collected on balances 2 and 3 as well as their Collection rates, and the totals of both.
- When finished with a run, click on File-Save as: and choose an appropriate file name. When ready for another run, simply press the “Clear Data” button, or close and re-open the file.
- The **STOP** and **RUN** keys on the FilterTec Plus front panel may be used to interrupt the filtration process. This will only cause minor changes in the data and charts. They show up in the data set by displaying the word PAUSE in the ST (Status) column of the Data worksheet.
- Using the **EXIT** key however and then pressing Exec and RUN again in the same data collection run, will replace the header information in the text box at the top of the worksheet, while continuing to add data to the bottom of the sheet. It is recommended that you either save the data as mentioned above, or dispose of it by clicking on the “Clear Data” button prior to pressing the Exec and RUN keys again to begin a new set of data.
- The FilterTec Plus allows the Constant Rate or Pressure to be changed on the fly by pressing the RATE/PRESSURE key on the front panel. This is a very useful tool in determining the optimum parameters for a process. When this key is pressed, the FilterTec Plus will stop sending data to the worksheet until approx 15 seconds after having pressed the “Select” button on the front panel to finalize the choice. As the process is continuing while this is done, the data will reflect the change.

Please contact Scilog customer service at 800-955-1993 if you have any questions, comments or suggestions regarding the use of this data collection software.

7.2 PC HyperTerminal Settings:

FilterTec Plus to PC: For PC Connections via the Printer Port a SciLog RS-232 Cable (P/N: 080-073) is needed. When not using the SciLog printer, this allows process data to be “dumped” into a PC for archiving. The list of settings below must match those in Setup: Printer of the FilterTec Plus, and Print Delay should be set to “0”. Alternatively, the USB port may be used. The driver for the USB connection is on the CD this manual is on, and may be downloaded from www.scilog.com.

The following terminal setting procedure is intended for PCs with a **Window 98/XP** software installation: Press the **START** button in the lower left corner of your screen, select “**Programs**” then select and open “**Accessories**”, select “**Hyper Terminal**”.

If using **Vista**, HyperTerminal Personal Edition can be downloaded from the internet at: <http://www.hilgraeve.com/hyperterminal.html>

From the “**Connection Description**” screen, select an icon and enter a file name, i.e. FilterTec Plus. Press “**Ok**”

From the “**Connect To**” screen, select “**Direct to Com 1**” in the box labeled “Connect Using” or the Com Port assigned to the FilterTec Plus and Press “**Ok**”.

From the “**Com 1 Property**” screen, select the following parameters

Bits per Second:	9600
Data Bits:	8
Parity:	None
Stop Bits:	1
Flow Control:	None
Press “Ok”	

Press “**Ok**” at the bottom of the “FilterTec Plus Setup” screen.

A window with a blinking cursor will be presented, and the data stream from the FilterTec Plus will be displayed as it occurs.

Appendix “A” Application Examples

The FilterTec Plus allows filter capacity determinations to be carried out by the following methods:

1. Constant Pump Rate
2. Constant Pump Rate followed by Constant Pressure
3. Constant Pressure, V_{max}
4. Programmable Step/Scan Rate/Pressure

The data obtained from these methods is used to determine optimal filtration conditions to process a given volume of solution by dead-end filtration. The desired information includes answers to the following questions:

- a. What is the optimal filter porosity?
- b. What is the required filter area?
- c. What is the required filtration time?

FilterTec Plus Parameters: When utilizing the FilterTec Plus for filter capacity determinations, a few, simple rules must be observed:

1. Selection of Pump Tubing: CP120, 160 RPM Pump Motor, Tandem 1081

The pump tube selection should be made based upon the desired / required pump output range. Do not operate the FilterTec Plus at excessively low pump rates for any pump tubing you may have selected. For example, the Masterflex tubing size #14 has an output range from 2.0 to 35 ml/min, however, pump rates below 10 ml/min are better implemented with #13 tubing because its lower pump output capabilities and greater dynamic range. If you wish to implement a flow rate of 5.0 ml/min, #14 tubing has remaining dynamic range from 5.0 to 2.0 ml/min (stalling speed) where as #13 tubing has a remaining (ten-fold) dynamic range from 5.0 to 0.5 ml/min.

The dynamic range of the selected pump tubing is particularly important in the Constant Pressure Mode (V_{max}) as well as the Constant Rate/Pressure Mode. In both cases, the pump output decay is monitored over time. In order to record the lower end of the pump rate decay curve it is useful to utilize the widest possible dynamic range.

- For Pump Rates < 10 ml/min (160 RPM Motor) use Masterflex Tubing #13
- For Pump Rates 10 – 35 ml/min (160 RPM Motor) use Masterflex Tubing #14
- For Pump Rates 35 - 129 ml/min (160 RPM Motor) use Masterflex Tubing # 16
- For Pump Rates 129-283 ml/min (160 RPM Motor) use Masterflex Tubing # 25

2. Small Filter Area < > Low Pump Rate Large Filter Area < > High Pump Rate	Effective Filter Area: (SFCA)*	Recommended Masterflex Tubing Sizes:
15 mm Diameter Syringe Filter:	1.7 cm²	#13
25 mm Diameter Syringe Filter:	2.8 cm²	#13 or #14
50 mm Diameter (Barb) Filter:	20.0 cm²	#16

NOTE: The Effective Filter Area may be different for your particular filter. Check with the manufacturer of your filter. If you use the SciDoc documentation software, enter the Effective Filter Area in the “Operator Information” box under “Membrane Surface Area, Square Meter”; e.g. 2.8 cm² is entered as 0.00028 m².

* Depending on the filter porosity, filter material and filter housing, the Effective Filter Area may differ substantially from geometric filter surface area.

The following diagrams show the various configurations of the FilterTec Plus system.

This is the most common setup, using a single filter and pressure sensor.

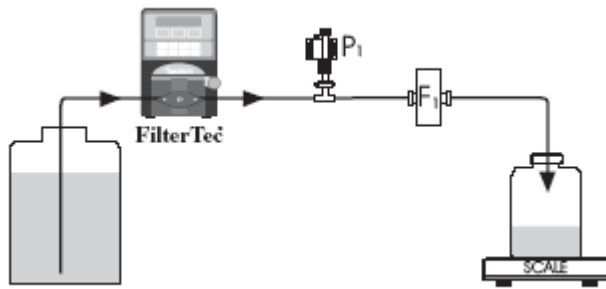

This is the other common setup, for testing a filter-train, using 3 filters and 3 sensors in series.

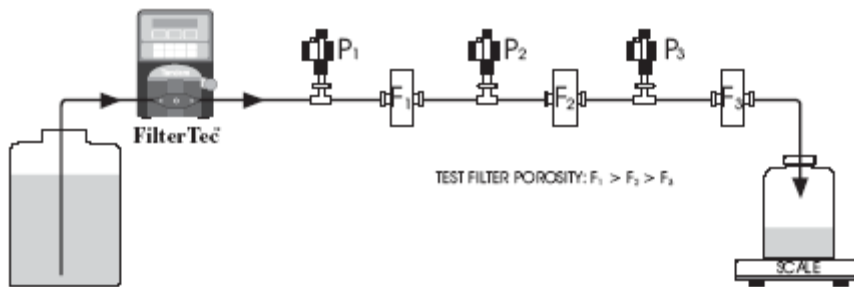

These may be augmented by use of a 6-way Rotary Valve to change from one solution to another in a programmed manner, using the Programmable R-P Mode.

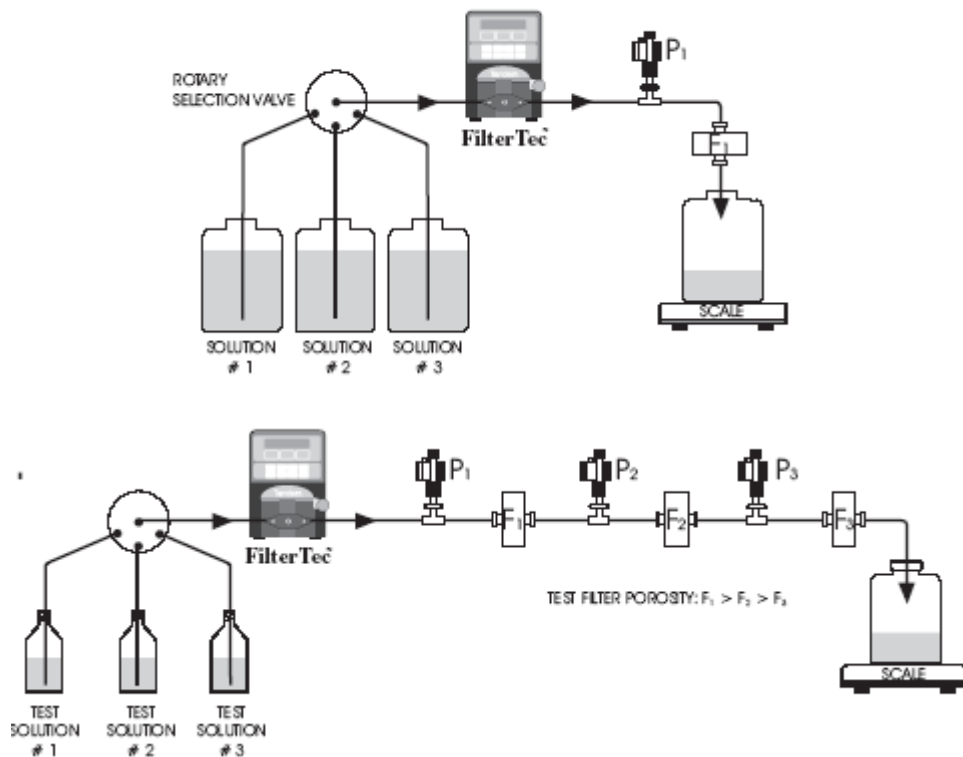

FilterTec Plus Settings and Parameters Worksheets

Filter

Filter Cartridge	
Filter Area, sq M	
Manufacturer	
Pore Size	
Max Psi	
Usual Operating Psi	

Programmable R-P Mode

Pump Tubing		
Response Factor		
Rate Scan:Initial Rate		
Rate Scan:Final Rate		
Pressure Scan: Initial psi		
Pressure Scan: Final psi		
Alarm Enable / Limits	Enable	Limit
Cumulative Volume		
Filtrate Weight		
Run Time		
Hi Pressure		
Low Pressure		
Low Flow		
Hi Temp.		

Rate / Pressure Mode

Pump Tubing		
Pump Rate		
Response Factor		
Alarm Enable / Limits	Enable	Limit
Cumulative Volume		
Filtrate Weight		
Run Time		
Hi Pressure		
Low Pressure		
Low Flow		
Hi Temp		

Constant Pressure Mode

Pump Tubing		
Pump Pressure		
Response Factor		
Alarm Enable / Limits	Enable	Limit
Cumulative Volume		
Filtrate Weight		
Run Time		
Hi Pressure		
Low Pressure		
Low Flow		
Hi Temp.		

Filter

Filter Cartridge	
Filter Area, sq M	
Manufacturer	
Pore Size	
Max Psi	
Usual Operating Psi	

Programmable R-P Mode

Pump Tubing		
Response Factor		
Rate Scan:Initial Rate		
Rate Scan:Final Rate		
Pressure Scan: Initial psi		
Pressure Scan: Final psi		
Alarm Enable / Limits	Enable	Limit
Cumulative Volume		
Filtrate Weight		
Run Time		
Hi Pressure		
Low Pressure		
Hi Temp.		
Low Flow		

Rate / Pressure Mode

Pump Tubing		
Pump Rate		
Response Factor		
Alarm Enable / Limits	Enable	Limit
Cumulative Volume		
Filtrate Weight		
Run Time		
Hi Pressure		
Low Pressure		
Low Flow		
Hi Temp.		

Constant Pressure Mode

Pump Tubing		
Pump Pressure		
Response Factor		
Alarm Enable / Limits	Enable	Limit
Cumulative Volume		
Filtrate Weight		
Run Time		
Hi Pressure		
Low Pressure		
Low Flow		
Hi Temp.		

Appendix B: Troubleshooting

A. Peristaltic Pump Heads

When this occurs:	Check the following:	Possible Solution
When “Check Pump Head” error occurs with your peristaltic head.	<p>Does “Check Pump Head” occur with no tubing in the head?</p> <p>Confirm the tubing sizes you are using.</p>	<p>If it occurs with no tubing in the head, call SciLog. You may need a new motor.</p> <p>If no, make sure you are using the correct size tubing. Thick walled tubing in a thin wall pump head will cause this, and may break the head</p>
When peristaltic pump head turns, but no fluid flows.	<p>Check the tubing size and pump head type, as you may be using the wrong size for that head.</p> <p>Tubing Size is ok</p>	<p>Tandem 1081 is for thin-walled tubing, and 1082 is for thick-walled tubing. Thin-walled tubing in a thick walled head won’t produce much flow. Use the correct size tubing.</p> <p>The pump head may be cracked from being forced closed with the tubing crosswise or the wrong size tubing. Contact Scilog for repair or replacement parts.</p>
When the pump head turns ok with no tubing installed, won’t turn when you put tubing in, and you don’t get a “Check Pump Head” error.	The coupler is loose or broken.	Contact SciLog for tech support, or to arrange for service and an RGA#

When this occurs:	Check the following:	Possible Solution
<p>When “Scale Error” “Hit any key” shows on your screen.</p>	<p>Is your scale turned on, and are the cables tight?</p> <p>Ok, the scale is on, cables are ok, and it still won’t work?</p> <p>Ok, the scale is chosen correctly, and it still doesn’t work. Now what?</p>	<p>Press any key to clear the error, tighten the cables, turn on the scale, and try it again.</p> <p>Refer to Section 5, Setup: Scale of this manual, then go to Setup Mode of the pump, select Scale, then Scale Mfr, and confirm the selection is correct.</p> <p>Either refer to the same manual section mentioned above to check the scale settings, or call SciLog tech support for help correcting them if you are not using the default scale.</p>
<p>When the pump is acting weird. The flows and pressures are all wrong; it gets data from the balance, but slows down way to early; etc.</p>	<p>Has someone messed with your FilterTec Plus?</p> <p>Have you had electrical problems in the building lately?</p>	<p>If someone other than yourself or your supervisor has changed the settings without your knowledge, you can to return them to their original settings.</p> <p>Power spikes and brown outs can cause problems. Enter Setup; Pump, and then select Factory Reset. This step is a last resort. This will return the unit to the factory default values. You will need to return to Setup; Pump; Motor RPM, and verify its setting, as well as Setup, Pump; Pump Head to verify it as well. Call SciLog tech support if needed.</p>

B. Piston and Magnetic Gear Heads

When this occurs:	Check the following:	Possible Solution
When "Check Pump Head" error occurs with your piston or magnetic gear head.	<p>When was the last time you had the head serviced?</p> <p>Are you pumping a gritty solution, or one that can crystallize if allowed to dry out?</p>	<p>If you believe the head is stuck due to being dried out, you can try wetting it by placing an appropriate solvent in the upper tubing overnight.</p> <p>If it still won't turn, contact SciLog to arrange an RGA to send your pump in for service, or purchasing a service kit if you have a magnetic gear head.</p>
When your piston pump head seems to turn and the motor runs, but no fluid flows.	Either the piston is broken, or the coupler is loose.	Contact SciLog for tech support or to arrange for service for your pump and RGA#
When your magnetic pump head seems to turn and the motor runs, but no fluid flows.	<p>Has the unit run dry?</p> <p>Is it a high viscosity fluid?</p>	<p>Magnetic gear head pumps do not dry prime well after they have been broken in. You must keep the pump wet. Be sure you are using a check valve as your dispensing tip so the fluid doesn't run back into the container.</p> <p>Magnetic gear heads do not perform well with viscous fluids, as they can de-couple. Either reduce the viscosity, provide head pressure, or choose a different style of head.</p>

C. SciDoc Documentation Software

When this occurs:	Check the following:	Possible Solution
When you get a “Device Error, Com Port Not Available” error from your computer.	This is a computer related error, not one generated by the pump. The Com port you specified is in use or does not exist on your computer	<p>Check Device Manager from the properties page of the My Computer Icon. Expand the + next to Ports, Com and LPT. What Com ports exist, and are they functioning properly?</p> <p>If all in Device Mgr is fine, then some other program is using the Com Port, consult your IT or MIS dept. for assistance. You may have to specify a different Com Port for use with the SciDoc spreadsheet.</p> <p>Known devices/programs that cause this error:</p> <ul style="list-style-type: none"> • Installed but not used Serial Mouse. • RS-232 bar code reader installed on the same Com port. • Hot Sync or Synchronize program for your PDA. • An already open instance of SciDoc using that Com port.
When this occurs:	Check the following:	Possible Solution
You have SciDoc open, and the FilterTec Plus running, but no data is being collected.	<p>There is no communication between the spreadsheet and the FilterTec Plus. Check that you are using the correct cable, and that it's installed correctly</p> <p>WinWedge may not be running.</p> <p>WinWedge may not be able to access the Com Port.</p>	<p>The RS-232 cable for the PC can look nearly identical to that used for the balance. They should be labeled..</p> <p>Check the System Tray for the WinWedge Icon. If it's not there, click on the Setup Button, and indicate which port you are using.</p> <p>You will find a button on the Taskbar indicating a “Device Error”, refer to the previous troubleshooting subject for help with Com Port errors.</p>

D. FilterTec Plus Specific issues

When this occurs:	Check the following:	Possible Solution
<p>You have a balance in use, but aren't getting any data from the balance.</p>	<p>Is it connected and configured correctly?</p> <p>Did you turn the Filtrate Weight Alarm off?</p>	<p>Review suggestions for the "Scale Error" problem listed above. If your not getting this error, see #2 that follows.</p> <p>If the Filtrate Weight Alarm under Alarm Enable: Filtrate Wgt. Is set to OFF, the unit will not look for the balance, and not gather data from it.</p> <p>The lack of "Scale Initialization" occurring is a good clue. Set this alarm to either Alarm Only, or Pump Stop. If you don't want the alarm to occur, set the Limit to either 0.0 or well beyond anything you might collect.</p>
<p>The pressure reading is always 0.0, even when the sensor is disconnected.</p>	<p>This occurs when the sensor is Zeroed when not connected, or Span is pressed instead of Zero, thereby setting the max input to a zero value.</p>	<p>You must perform a Factory Reset to correct this.</p> <p>Following the Reset, verify the Motor RPM setting, and be sure to only Zero the sensors when they are connected!</p> <p>Do not use the Span button unless the Pressure Sensor inputs are being calibrated.</p>